

NOTES:

KEVIN'S WEBSURFER HANDBOOK II FOR CRYSTAL RADIO

DESIGN – THEORY – TESTING



Kevin Smith
2011

NOTES:

Printing / Binding Instructions

1. Choose “fit to page” in print menu
2. Print document double sided on letter size paper
3. Cut the entire printed document in half
4. Fold over making sure the page numbering is continuous
5. For the cover: Print just the first page on card stock paper
Cut the cover in half as well
6. Assemble the covers on the document
7. Punch the left side for a binding, spiral or comb as desired

<http://www.lessmiths.com/~kjsmith/crystal/catalog.shtml>

KJ Smith

INTRODUCTION

The contents of this handbook consist of a number of web-based documents that provide significant and detailed insights into the design and theory of crystal radio. For the crystal set hobbyist, it is not sufficient to build from kits or merely follow published instructions or designs. It is important to gain deeper understanding of the theory behind the sets and learn from experienced members, to learn about the tricks and tips they employ to construct interesting and advanced sets. The web is a marvelous source of data and information. Many long-time crystal set builders have created dedicated sites to disseminate information and resources, to share their creations.

To further my understanding I have spent many long hours surfing the many excellent crystal radio websites. The wealth of information is outstanding, even a bit overwhelming at times. Pages range from simple to advanced, up to pages where one likely needs their EE degree to comprehend the material. When I first started I spent time on the basic web pages, but as I grew comfortable and began to consider more advanced features for my sets, I spent ever more time on more advanced web pages. Whenever I found material especially well presented and useful, I would print it out into notebooks and study for hours at a time. With time I came to find that within the large number of web resources available, there exists a canon of sites particularly well suited for study. While my personal needs and tastes ultimately dictate those pages I find useful, I do believe that these pages are the best of the lot.

In this booklet I have taken the sections that I spend most time studying and have arranged them into sequence from basic theory and design considerations to more advanced material on particular aspects of the hobby. Finally I include several sites with advanced methodology for testing and experimenting with the sets I have built. Each section is useful and understandable to the hobbyist with moderate to good experience. The handbook will help the beginner to quickly get up to speed and allow the experienced builder to find endless new ideas. This is not a book of Hookups or circuit designs, that is covered in my Catalog of Crystal Hookups.

All of the material in this handbook is copyright for which I have not sought permission. Therefore this is not presented for publication or copy. It is only my personal resource. I encourage anyone finding this copy to pursue ON THE WEB the web pages identified within. I include the name of the author and web address of each section. I wish to sincerely thank every author presented for their excellent pages and ask forgiveness for my editing into this handbook.

Kevin Smith
2011

www.lessmiths.com/~kjsmith/crystal/cr0intro.shtml

Dielectric losses in coils.

When a coil is wound on a coilformer, there will be dielectric losses in the former. Also in the insulation of the wires there will be dielectric losses, especially when windings are touching each other.

For the coilformer it is important to use a material with low DF value, and to use as few as possible of this material between the windings so the capacitance and losses are kept to a minimum.

Other dielectric losses.

Also in the wires in the receiver dielectric losses can occur. For instance if a wire carrying radio frequencies is placed very close to a other conductor. The two conductors form a capacitor, with the wire insulation as insulator, in this insulation losses can occur.

We can reduce these losses by placing the wire at some distance of the other conductor (some cm. or more).

If we connect this capacitor to a coil, then we have a LC circuit. If the coil has no loss, the maximum Q of the LC circuit will be:

$$Q = Z_c / R_s = Z_c / (Z_c \cdot DF) = 1 / DF$$

So, if we use a capacitor with nylon insulation, the Q of the LC circuit will have a maximum value of: $Q = 1 / 0.026 = 38$. This is a very low value.

So, a LC circuit with airspaced tunercapacitor has a infinite Q??? No, because there are more losses, like the resistance of the coilwire, the resistance of the capacitor plates, the dielectric losses in the coil, etc.

It is also not possible to use a tunercapacitor with only air insulation. The rotor (turnable part) and stator (non turnable part) must also be connected to each other by insulation material. If for instance 4/5th of the capacitance is caused by air insulation, and 1/5th by nylon insulation blocks, then the Q will increase by a factor 5 compared to a full nylon insulation. So the Q can then be $5 \times 38 = 190$.

The higher the frequency of the circuit, the higher the percentage of capacitance caused by the insulationblocks, and the lower the Q. Instead of nylon it is better to use a insulator with a lower DF value, and preferable also a low ϵ_r value.

For a high Q the following is also important:

Use the insulation material only on places where the distance between rotor and stator is high, this helps to reduce the capacitance and losses caused by the insulator.

Don't use more insulation material then necessary.

CONTENTS:

1	Crystal Set Design 102	
		Al Klase
11	Crystal Radio Antennas	Owen Poole
31	Crystal Radio DXing	Steve McDonald
45	The Crystal Radio Revisited	Smith-Kettlewell
75	Designing an air-core Inductor	Kenneth Kuhn
89	Antenna Matching	Kenneth Kuhn
93	Variations: Slider-Tuned Set	Owen Poole
97	A Crystal Radio Wave Trap	Owen Poole
103	Bandspreading Techniques	Owen Poole
109	Selectivity Enhancement Circuits	Dave Schmarder
113	Contra Wound Coils	Dave Schmarder
125	Basket/spiderweb coil design	PA2MRX
139	Dedicated Impedance Matching	Darryl Boyd
159	Designing a DX Crystal Set	Mike Tuggle
169	Lyonodyne Version 17 Crystal Set	Mike Tuggle

177	Testing your Crystal Set	Owen Poole
187	Crystal Set Testing	Charles Lauter
199	Radio Test	Kevin Smith
213	Measuring the Q of LC circuits	Dick Kleijer
217	Diodes	Dick Kleijer
227	Diode I/V Characteristic	Kevin Smith
233	Experiments, antenna tuner	Dick Kleijer
237	Experiments with a detector unit	Dick Kleijer
239	Resonant Circuit	Kenneth Kuhn
249	Tuned LC circuits	Dick Kleijer
257	Coupled circuits	Dick Kleijer
263	Insulation materials	Dick Kleijer
269	Notes	

Nylon	3.33	0.026
Plexiglas:	2.76	0.014
Polyethylene (PE)	2.26	<0.0002
Polypropylene (PP)	2.25	<0.0005
Polystyrene (PS)	2.56	<0.00007
Polytetrafluoroethene (PTFE, Teflon)	2.1	<0.0002
Polyvinyl chloride (PVC)	2.88	0.016

A capacitor will have at certain frequency an impedance of:

$$Z_c = 1 / (2 \cdot \pi \cdot f \cdot C)$$

Z_c = impedance of the capacitor (Ohm)

$$\pi = 3,14$$

f = frequency (Hertz)

C = capacitance of the capacitor (farad).

Because of the losses caused by the insulator, it looks like there is a resistor connected in series with the capacitor. This is the series resistance (R_s) of the capacitor.

If the insulation of the capacitor has a certain DF value, the series resistance will have a value of:

$$R_s = Z_c \cdot DF$$

In the ideal case a capacitor has no loss, if we send a AC current through the capacitor there is no loss of energy. In practice there will always be losses, if we send a current through the capacitor a part of the energy will get lost by heating up the capacitor.

These losses are caused by:

- a- The resistance of the conductors (plates), these losses are left out of consideration here.
- b- The dielectric losses in the insulation. One insulator gives more dielectric losses than the other, this is indicated by the dissipation factor DF. The dissipation factor "DF" is sometimes also called: "tangens delta".

The lower the value of DF, the better the quality of the insulator.

In the following table some values of ϵ_r and DF for different insulation materials.

Material	Dielectric constant at 1 MHz. (ϵ_r)	Dissipation factor (DF) at 1 Mhz.
Vacuum:	1.000000	0.00000 ?
Air:	1.000585	0.00000 ?
Acrylonitrile butadiene styrene (ABS)	2.8 -- 3.8	0.006 -- 0.011
Glass	4.84	0.0036

CRYSTAL SET DESIGN 102

Copywrite 1997, 1998 - Alan R. Klase - All rights reserved.
<http://www.skywaves.ar88.net/xtalset102/xtalset102.htm>

Introduction:

Welcome to Crystal Set Design 102. It is assumed that you've already completed the 101 level course elsewhere, and know, at least, something about electronics in general and crystal radios in particular. If not, hit the books. The stuff in your public library will get you started. The early chapters of the "Radio Amateurs Handbook" are especially concise and approachable.

I've been a little disappointed at the lack of meaningful crystal set technical information on the web and in current literature. This is my attempt to at least partially remedy this situation. This work is the result of about ten years part-time investigation of crystal radios from an engineering perspective. Serious development of passive receivers pretty much came to an end with the introduction of reliable vacuum tubes around 1920. A lot of crystal sets, both commercial and home brew, have been designed in the interim, but most are mediocre performers. So the mission turned out to be one of rediscovering the the secrets of the age when spark was king.

Getting Started:

My approach is to build crystal radios out of quality vintage radio parts. They are available in great profusion at amateur radio "hamfests" and antique-radio meets (and in my garage). If you don't have access to these sources, I'd suggest you start at Radio Shack: Buy their Crystal AM Radio Kit, 28-177, for \$6.99. This is actually not a bad crystal set, and it contains a coil, a variable capacitor, a germanium diode, and, most importantly, a reasonably sensitive high-impedance ear phone. You're also going to need an antenna. This generally means wire up in the air. The attic may be the next logical alternative. Apartment dwellers may be in trouble unless you're near an AM radio station, or can arrange a "stealth" antenna of some sort.. Again, if you don't (yet) have a junk box, get Radio Shack's Outdoor Antenna Kit, 278-758, for ten bucks. Wire has always been expensive, and hard to find retail, so keep your eyes open for bargains. Another RS item, that's almost indispensable, is a set of mini-alligator jumper cables, 278-1156, 10 for \$3.99. These are how you make temporary "breadboard" hookups while experimenting with new circuits. You'll also want basic electronic hand tools and a soldering iron.

Circuits:

The simplest radio you can build is just a diode detector and a headset. With a reasonable antenna and ground you will hear the strongest stations, albeit all at once. This is not much of a

INSULATION MATERIALS

Dick Kleijer crystal-radio.eu

<http://www.crystal-radio.eu/enisolators.htm>

For insulation materials used in crystal receivers the following electrical properties are important: insulation resistance, dielectric constant and dissipation factor.

Insulation resistance.

This is the resistance between two conductors having a insulation material in between. In most cases the insulation resistance is high enough for use in crystal receivers.

Dielectric constant.

Two conductors with insulation in between form a capacitor. If the conductors have the shape of parallel plates then we can calculate the capacitance as follows:

$$C=0.0885 \epsilon r A / d$$

C= capacitance in pF (picofarad)

ϵr =dielectric constant of the insulator (ϵ = the Greek letter Epsilon)

A= area of the plates in square cm. d= thickness of the insulation in cm

The value of ϵr indicates the increase of capacitance compared to air insulation.

Dissipation factor.

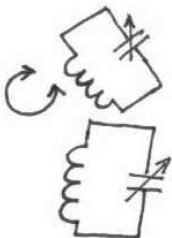

Capacitive coupling

Coupling is adjusted by a variable capacitor with a very low value (e.g. 1 pF). There must be no coupling via the magnetic field, so the coils must be placed at a right angle. Capacitive coupling is also useable when magnetic coupling is difficult, for instance when using ringcore or potcore coils.

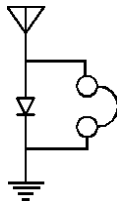

radio, but it will give you some indication that you have enough signal strength to continue experimenting.

The primary problem with the above set is that it offers no selectivity. We'll solve this problem by building a tunable filter. This will generally consist of a coil and a capacitor forming a tuned circuit. Either the capacitor or inductor, or both need to be variable so circuit can be tuned to different stations. The classic values are 250 μH and 365 pF to tune the broadcast band. This is the basic crystal set schematic you'll find almost everywhere. It works better than just a diode, but has some serious shortcomings that are easily remedied.

The Importance of Impedance Matching:

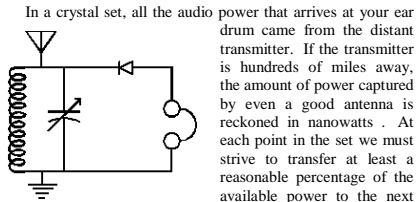

In a crystal set, all the audio power that arrives at your ear drum came from the distant transmitter. If the transmitter is hundreds of miles away, the amount of power captured by even a good antenna is reckoned in nanowatts. At each point in the set we must strive to transfer at least a reasonable percentage of the available power to the next

stage. Perfect impedance matching is not necessary, don't fret over a 2 to 1 mismatch, but let's eliminate as many of the 10 to 1 and 100 to 1 mismatches as we can.

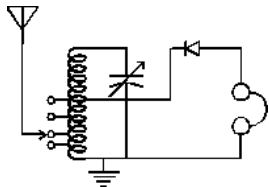

Single-Tuned Sets

In the case of the simple set in the last example, let's

do two things: Tap the antenna input "down" on the coil. The impedances of the antenna and tuned circuit will vary with frequency, so it's a good idea to provide multiple taps and a selector switch or movable jumper. As a starting point tap the coil at about 5%, 10%, 20%, and 50% of the total number of turns from the ground end of the coil. Secondly, connect the detector to the 50% tap. This does two things, both of them beneficial: It provides a better match to the detector when it's connected to the usual sort of crystal set headphone that has an impedance of about 10K ohms, resulting in a louder signal. It's also reduces the loading on the tuned circuit, increasing it's Q and consequently it's selectivity.

These improvements result in a better than average crystal radio. With 50-75 feet of wire up in the air, you should hear daytime 50KW stations out to 40-50 miles, and night-time skywave stations will come in from hundreds of miles away. This is essentially the circuit I arrived at for my Cub Scouts a few years back. (See *The Den Two Crystal Radio* in *Crystal*

There are several methods for adjusting coupling. The methods shown below are mostly used in crystal receivers.

The coils are side by side
Coupling is adjusted by varying the distance between the coils.

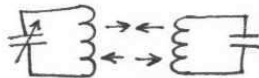

Coils behind each other.
Coupling is adjusted by varying the distance between the coils.

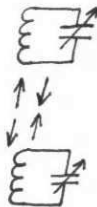

One coil is turnable.
Coupling can be adjusted by varying the angle between the coils. With both coils in the same direction, the coupling is maximal. Turning the angle towards 90 degrees, the coupling will decrease. With an angle of 90 degrees, there is no coupling at all.

Overcoupling

The coupling is too high because the distance between the coils is too small.

The bandwidth is too high.

The curve shows two peaks, the higher the the coupling, the higher the distance between the peaks, and the deeper the dip between the peaks.

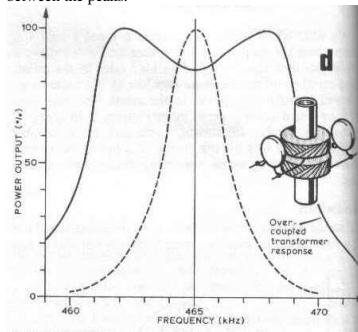

Set Projects published by The Xtal Set Society) You'll also notice it's almost exactly the same circuit used in the Radio Shack set

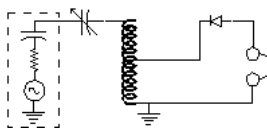

Another effective way to match the antenna to the tuned circuit is to use a variable capacitor as shown in the drawing. A cap in the 300-500 pF range is appropriate. Tune in a station then change the coupling and retune and see if there's an improvement. Some sets

have the coupling capacitor in the ground lead instead of the antenna lead.

Electrically it's the same thing, but sometimes it's more convenient for mounting and grounding and eliminating hand

capacitance effects.

capacitance effects.

With the previous circuit, connected to a good sized antenna, you'll find you can set the tuning capacitor to it's minimum value, or even remove it completely and still get good performance. To understand how this "series tuned" receiver works, I've inserted the equivalent circuit of the antenna in the drawing. Any Macroni antenna less than a quarter wavelength

long appears to be a capacitor in series with a small resistor, known as the radiation resistance of the antenna, and an RF voltage source. This is almost always the case as a quarter wavelength, even at the top of the broadcast band, is 187 feet. Our aim is to make as much RF current as possible flow from our antenna. When the series value of the antenna and tuning capacitors and the inductor are tuned to the frequency of interest, the inductive and capacitive reactance's cancel out, leaving only the DC resistance of the inductor. This results in maximum current flow in the tuned circuit, and maximum voltage applied to the detector. A receiver of this sort will usually require a variable inductor to cover the entire broadcast band. In such cases, keeping the detector connected to the optimal point on the coil presents challenges.

One classic variation on the series tuned receiver, known as the "two-slider tuner", dispenses with the tuning capacitor entirely. Instead a sliding contact on the coil varies the inductance in the antenna circuit.

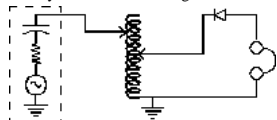

A second slider connects the detector at the best point on the coil. Total

inductance should probably be the better part of a millihenry

Critical coupling

There is maximal powertransfer.

The bandwidth is higher than in a single circuit, and also also higher than a undercoupled circuit.

The response curve is flat in the top over a small part.

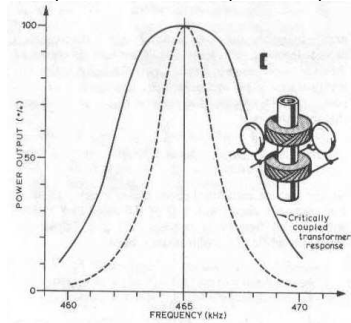

Undercoupling

The coupling between the circuits is too low, because the distance between the coils is too high.

There is no maximum power transfer from one coil to the other.

The bandwidth is higher compared to a single circuit.

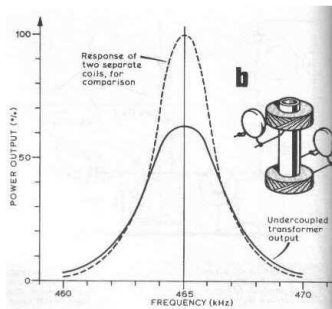

Yet another, historically common circuit, connects the detector in series with the variable inductor. This is not such a great idea from the standpoint of impedance matching, but it is simple. Series tuned sets all have difficulties with short antennas, because their capacity is low.

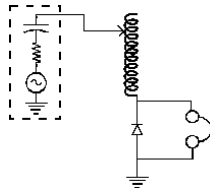

Another way to implement the series tuned set, that improves the match to the detector, is to connect the detector and headset across a second coil in the series circuit. For the broadcast band, this coil has a fixed value of approximately 80 μH . The variable capacitor is optional, especially if the larger inductor is continuously variable.

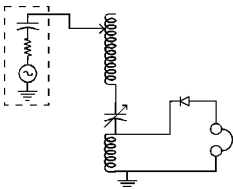

Single-tuned crystal sets, whether series or parallel tuned, leave a lot to be desired in terms of selectivity. Yes, the nose selectivity can be improved by increasing the Q of the tuned circuit, but the skirt selectivity remains hopelessly broad. The obvious solution is to use more than one tuned circuit. The point of diminishing returns is between 2 and 3 circuits for a crystal set due to cumulative losses and tuning difficulties.

The Two Circuit Receiver

The classic solution is the "two circuit" tuner. The antenna circuit is series tuned by a variable capacitor and an inductor, while the detector circuit is connected to a parallel LC circuit. The amount of mutual inductance, or coupling, between the primary and secondary circuit is generally made variable. This allows light coupling to be used to obtain the sharpest tuning, while increasing the coupling increases sensitivity at the expense of selectivity. This is essentially the same architecture used to great effect in the communication receivers of the wireless era. If you're seeking better performance for your crystal set this increased complexity is well worthwhile.

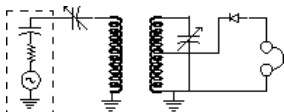

There are several ways to implement variable coupling in the two-circuit set. The navy style "loose couplers" used a secondary coil that telescoped inside the primary. Other possible schemes include variable taps on the low end of the secondary coil, link coupling between the two coils, or the use of a small variable inductance common to both circuits.

COUPLED CIRCUITS

Dick Kleijer crystal-radio.eu

<http://www.crystal-radio.eu/enkoppelfactor.htm>

In a receiver having two tuned circuits, both circuits must be tuned to the same frequency. The 2 coils of the tuned circuits must have a certain distance in between, via the magnetic field around the coils, the circuits are coupled to each other. The distance between the coils determines the degree of coupling, the smaller the distance, the higher the coupling.

The -3dB bandwidth of a coupled circuit is higher than with a single tuned circuit.

The suppression of frequencies at some distance from the tuning frequency is in a coupled circuit better than with a single circuit, this is good for suppressing strong local stations.

In the pictures below you see the response of the coupled circuit at different degrees of coupling. For comparison the response of a single tuned circuit is shown as a dotted line.

The pictures are taken from a radio handbook, and are about a coupled filter for 465 kHz, but the theory is useful for all coupled circuits, so also for crystal receivers with two tuned circuits.

Here we see, that at a constant value of R_p , the Q will decrease with increasing frequency (f). A parallel resistance across the circuit will especially give a reduction of Q at higher frequencies.

The value of Q will both depend on series and parallel resistance, it is possible that a LC circuit gives a increasing Q at increasing frequency (because of series resistance) and than Q will reduce (because of the parallel resistance). In this case we have a peak in Q somewhere in the frequency band.

Often the losses caused by the parallel resistance are the highest, and we only see a reduction of Q at higher frequencies in the medium wave band. Than there is also a peak in Q , but this occurs at a frequency lower than we use.

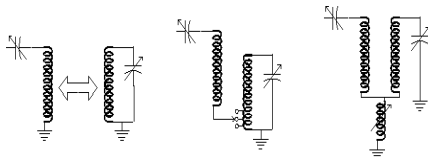

Variable coupling schemes for two-circuit tuners.

Additional Details

The primary inductance will want to have a maximum value of about 500 μH to reach down to 530 KHz. However, a lesser value is needed to reach the 1600 KHz end of the band. I've been building coils with five or six evenly spaced taps. This lets you tune around for an optimum match to the antenna.

Install a DPDT switch to allow the primary circuit to be operated in a parallel-tuned mode: The input end of the primary capacitor is grounded, and the antenna attached to the top of the coil. This allows effective operation with short antennas.

If a non-fixed detector is used in a double-tuned circuit, it's a good idea to include a buzzer to generate a local signal to adjust the detector. The circuit is a low-voltage mechanical

buzzer, a battery, a push-button switch, and a one-or-two-turn link to the secondary coil. A low voltage relay with it's normally-closed contact wired in series with the coil is a good substitute for a buzzer.

insulators of the tuning capacitor Dielectric losses in materials placed near the coil or tuning capacitor, look [here](#) for more information about this subject. If the capacitor plates are not clean: dielectric losses in the dirt and oxide on the capacitor plates.

Also there can be a leaking resistance in insulators, e.g. by moisture.

All these losses together makes a parallel resistance (R_p) across the LC circuit.

Magnetic losses

This occurs when a magnetic material (iron) is placed near the coil. Non magnetic materials (plastic, wood, aluminium etc.) don't give magnetic losses.

Why is the Q factor not constant for all frequencies?

The series resistance R_s gives a reduction of Q. If we leave other losses out of consideration, the Q will have a value of:

$$Q = 2\pi fL / R_s$$

If the value of R_s is constant, the value of Q will increase with increasing frequency (f). A series resistance in the circuit will especially give a reduction of Q at lower frequencies.

On the other hand: if we only look at the losses caused by the parallel resistance R_p , the Q will have a value of:

$$Q = R_p / (2\pi fL)$$

$$R_s = (2 \cdot \pi \cdot f \cdot L) / Q$$

The Q factor of a unloaded LC circuit is determined by the following factors: series resistance in the circuit, parallel resistance across the circuit and magnetic losses.

The series resistance in the LC circuit.

the lower the series resistance the higher the Q. The total series resistance in the circuit (R_s) is the sum of:

The wire resistance of the coil, thicker wire or litzwire with much strands helps to reduce wire resistance.

The resistance of the capacitor plates, silvered plates gives the lowest resistance. Plates with oxide gives more resistance than clean plates.

Contact resistance between rotor and frame of the variable capacitor, preferable the variable capacitor has a spring connected to rotor and frame, this provides a low resistance. When the contact is made with a slidercontact at the rotor, this must be clean and free of oxide.

The parallel resistance across the LC circuit.

the higher the parallel resistance, the higher the Q.

Parallel resistance across the circuit (R_p) is caused by dielectric losses.

There are: Dielectric losses in the coilformer Dielectric losses in the insulation of the coilwire Dielectric losses in the

CRYSTAL RADIO ANTENNAS

Owen Poole

<http://bellsouthpwp2.net/w/w/wuggy/antenna.htm>

If there is such a thing as the perfect antenna, then why does every issue of every ham magazine have an antenna article? Fortunately, for the crystal radio nut, most ham antennas are less than optimum for general listening use, and require special care and feeding due to the need to have the transmitter and antenna somehow matched to near perfection and for the antenna and its associated parts robust enough to handle power without arcing and sparking while also keeping the transmitted signal out of the shack and also out of the neighbor's tv set.

Crystal radio antennas have some special requirements:

- a. large frequency range
- b. large signal gathering capability
- c. efficient in getting and then transferring the received signal to the set.

Your basic problem is normally just getting enough wire in the air to have a resonant circuit. For 99 percent of us, the answer is: you can't. Even the shortest resonant antenna for the top of the AM broadcast band, a quarter wavelength *Marconi* antenna, would have to be about 137 feet long; the bottom of band calls for about 425 feet. Unless you are one of the fortunate few to be able to erect a bona fide antenna farm everything you do from this point on will be a compromise of one sort or another. This means you have to

start thinking about your antenna system rather than just what you hang up outside the house.

First, the antenna itself: I recommend you use stranded copper wire, at least 20 gage. Try to get at least 50 feet of it "out the window" and up in the air as high and as far from the house as possible. My experience is that anything shorter gets real hard to tune, and gives away a whole bunch of signal to boot. Longer is better, higher is better. Use plastic strips or ceramic separators or whatever you can get to ensure the antenna wire is not touching anything that could be grounded, including the tree you may be using for a support. I usually just use stranded wire with a tough plastic coating, wrapping it over tree limbs as I go, and connect it at the far end with heavy nylon fishing line. **Do not go over or under power lines.** If you are coming in through the bottom of a window, as many of us do, be sure to use insulated wire for the final lead in. If you have to put it inside, such as up in the attic, make sure you are not hanging it under a metal roof or ridge vent, otherwise it could very well shield your wire from the signals you are trying to get. High straight antennas are probably best, but do the best you can, and don't be afraid to bend it in order to get more wire out there. Contrary to popular wisdom, you can tune a bent antenna. If you like to try out different stuff, put an alligator clip on the end in the shack to make quick connections to your latest xtal wonder rig. If you replace your antenna, or otherwise have room, a second antenna can come in handy, if for nothing more than comparison purposes. My second antenna consists of 50 feet of wire out the window, up to the roof, and over to a tree. This is about what I expect my students to get up, and I always use it for testing kid radios. If your main antenna is mostly long and horizontal, a shorter, and more vertical antenna might give some pleasant results,

The table below gives the value of impedance and voltage on the tap's of the coil. Also the current is given which can be given at the tap, the current will increase at a lower tap.

Tap	Voltage on tap	current	impedantie
100 %	100%	100%	100%.Rp
90%	90%	111%	81%.Rp
80%	80%	125%	64%.Rp
70%	70%	142%	49%.Rp
60%	60%	166%	36%.Rp
50%	50%	200%	25%.Rp

The used diode must also have about the same resistance as the impedance at the tap.

Because of the lower voltage at the tap's the diode efficiency will decrease however, and this will reduce the sensitivity of the receiver. The best option is the diode at the top of the coil, and the use of a load impedance with a high enough value.

Series resonance

In a series connected LC circuit, the impedance will be low at resonance. If there are no losses in coil and capacitor, the impedance will be zero Ohm at resonance. But here are also always losses, in serie resonance we keep a certain resistance R_s . The higher the Q , the lower the series resistance R_s .

The Q of a LC circuit will decrease when we connect a antenna or detector to it, this is because the antenna or detector gives extra parallel resistance to the circuit. By doing this the selectivity of the circuit will reduce.

Parallelresonance

In a parallel LC circuit, the impedance will be high in resonance.

If the coil and capacitor has no losses, the impedance would even be infinite at resonance. In practice this is not possible, there will always be losses, for instance in the resistance of the coil wire.

So, the impedance is not infinite, but has a certain value, it looks like there is a resistor connected parallel to the LC circuit, this we call the parallelresistance of the circuit "Rp".

$$R_p = 2 \cdot \pi \cdot f \cdot L \cdot Q$$

Parallelcircuit with taps on the coil

As described above the parallel LC circuit has a certain parallelresistance.

For maximum sensitivity in a receiver, the load impedance (speaker or audiotransformer) must have about the same value. If we only have a speaker or transformer with a lower impedance, then we can connect the detector diode at a tap on the coil, instead of the top of the coil. The circuit will then not be loaded too much, and the Q and selectivity will not drop.

particularly with distant stations and higher frequencies. Since you will probably be using what is considered a random wire antenna, connected at one end to the set, it may be of some value to know that the horizontal part of the antenna "points" in the direction of best reception off the free end.

Next, get a good ground. This is the other half of your antenna, and a good earth ground is essential. By earth ground I mean a good electrical connection to the earth. (I once had a student who tried just laying the ground wire on the ground - didn't work) I know of several hams who invest more time, effort and money in their ground than any other part of their antenna system. Mine is currently a tight connection to a close by cold water pipe. If you have plastic pipes, this doesn't work. I have also used pipes hammered into the ground, the ground rod the telephone company provides where their service comes into the house, and even the screw holding on the cover of electrical plug cover plates in a pinch (this is usually electrical ground, and may even lead electrically to the earth somewhere - works better for some locations than others). I haven't resorted to burying assorted lengths of wire in the ground yet, but many dedicated types do. If you are located in the desert or on a granite mountain, and good earth grounds are hard to come by, you need to read up on dipole antennas, ground radial systems and counterpoises; good luck. If you can not make a short connection to a good ground, and your ground lead is long enough to act as an antenna itself, you might want to try this trick: use a piece of coaxial cable between the set and the ground connection, using the inner core for the connection; connect the shield to the core at both ends with a capacitor, say, about 0.01 uF or so, to shield the ground lead from rf. I haven't tried this myself, but it makes sense, I think.

Whatever you have done up to this point, your antenna is (1) too long or too short (usually the latter), (2) is not resonant at the frequencies of interest, and (3) will not efficiently transfer whatever signals you get to your set. Guaranteed. Despite all these deficiencies, it will probably work pretty well, at least on the stronger stations. If you are happy at this point, declare victory and quit. If, however, you have a free hand left with which to flog yourself while you tune with the other, or really want to go after them, read on.

The first quick fix you can make is to effectively add additional length to your antenna by putting a large coil of wire between the antenna and the set. Wind 50 to 100 feet of 20 to 24 gage wire around a core between 2 and 5 inches in diameter, and tap it about every 10 turns or so. Attach one end of this coil to the antenna. Use an alligator clip to connect the xtal set to various taps until you get the loudest signal. While this doesn't add much to the antenna in the way of length, it can make the antenna closer to resonance with the frequency you are trying to dig out.

Quick fix number two, which can be done after or in lieu of number one, is to add some capacitance between the antenna and the set. This seems to work best if your antenna is too long for the frequency of interest. Radio Shack uses this technique in some of their Bunch-in-One electronic project kits, using a fixed 10 pF capacitor for a short antenna and a 100 pF capacitor for long antennas. Short refers to antennas 50 feet or less in length. I prefer to use a variable capacitor if I go this route. Putting the capacitor in series with the antenna this way lowers the inherent capacitance of the antenna. One of the more popular designs a number of years back put the

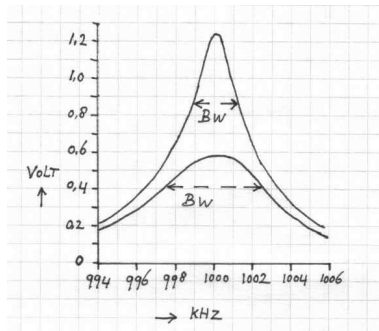

Curve of frequency respons for two tuned circuits.

At the upper curve, the bandwidth is 2.4 kHz.

The Q is $1000 / 2.4 = 416$

In the lower curve the bandwidth is 5 kHz.

And here the Q is $1000 / 5 = 200$.

The Q of a circuit can vary from less than 100 for coils made with massive wire, up to 400 or more for coils made with litzwire.

Bandwidth:

At resonance frequency the impedance of a parallel LC circuit will reach it's highest value, the voltage over the circuit will then also reach it's highest value.

Above and below the resonance frequency the voltage will decrease.

There are two frequency's where the voltage is 0.707 times the voltage at f.res.

One frequency is just below f.res, this is frequency fl.

And one frequency ia above f.res, this is frequency fh.

The voltage reduction to a factor 0.707 is a reduction of 3 Db

The current is there also reduced to 0.707, and so the power in the circuit is halve the power of f.res. ($0.707 \times 0.707 = 0.5$).

The bandwidth of the tuned circuit is: **BW =fh - fl**

Circuit Q:

The Q of the circuit is:: **Q=f.res / BW**

The higher the Q, the smaller the bandwidth, which is better for separating adjacent stations. And also, the higher the Q, the higher the voltage which the received station gives over the circuit, so a more sensitive receiver.

variable capacitor in between the xtal set and the ground connection. If it is the same size as the main tuning capacitor in the rig, you can even gang them and make tuning a bit less tiresome, with little or no adverse effect on results. This actually works very well. If you are using a set that has the detector or the antenna attached directly to the top of the tank circuit, and don't want to make taps in the tank coil for better impedance matching, this fix might be(I should say is) essential, and is certainly worth trying. The problem with connecting the antenna to the top of the tank circuit coil is complex, to say the least. I observed that the first effect is to lower the resonant frequency of the tank circuit drastically, even with a very short (a few feet) antenna. If you're going to try to get away with this, and don't have a variable capacitor to spare, you can make a gimmick capacitor by twisting a piece of wire connected to the set around the bitter end of the antenna. I did it another way, using some 18 gage twin lead wire; turned out that the capacitance of the twin lead was about 1.2 pF per inch, and the circuit resonance from the antenna was not affected if you used enough twin lead (one side connected to the set, the other to the antenna) to give you about 1 pF per foot of antenna.

Quick fix number three, which is an excellent idea even if you don't do the first two, is to connect the antenna to a tap on the tuning coil. This gives a better match between the impedance of the antenna and the tuned circuit of the rig. Techtronics does this with their nice little crystal set, providing two places to connect the antenna (really three, but they don't mention the third tap, for some reason. It is between the other two.) Probably the absolute worst place, in my opinion, to have the antenna connected is at the top of the set tuning coil along with the connection to the detector, yet that is what

several web page offerings would have you do. The tap you use will have to be determined experimentally, but I find that low on the coil close to ground helps.

Quick fix number four, which I recommend with fix number one: Use an antenna coupling coil . Wind the coupling coil on approximately the same diameter core as the main tuning coil, using about one turn for every six in the main tuning coil, and then put it in line (on the same axis) with the main tuning coil, with the ability to move them apart. You will get better selectivity, and can sharpen it up a bit more by moving the two coils apart - what the trade calls loose coupling. Oh yeah, the antenna and ground are connected only to the coupling coil, although you might try connecting the ground to the set as well. The "one for six" rule is just a rule of thumb. If you don't mind experimenting a bit, pick the number of turns on the coupling coil that gives you the best coverage across the band, particularly if you are going to use your set without a tuner. It will still be a compromise, and the best number of turns will depend on the length of your antenna and your location, but will give better results. Of course, you can dispense with the coupling coil if you are inductively coupling the antenna coil directly to the set's tank coil as in the basic tuner below.

If you have tried one or more of the tricks above, and are happy, fine. If not, I don't blame you, so it is time to get serious about tuning the antenna and coupling it to the set for optimum sensitivity and selectivity. In other words, it is time to talk antenna tuning and coupling methods, subtitled "how I went from 5 to 50 stations , and then to 98, heard on my xtal set".

TUNED LC CIRCUITS.

Dick Kleijer crystal-radio.eu

<http://www.crystal-radio.eu/enlckring.htm>

Frequency:

A tuned circuit made of a coil L (unit: Henry) and a capacitor C (unit: Farad) has the following resonance frequency:

$$f_{res} = 1/(2 \cdot \pi \cdot \text{root}(L \cdot C))$$

Example: a coil of 0.2 mH (0.0002 Henry) is connected to a 500 pF tuner capacitor (0.000,000,000,500 Farad).

The lowest frequency we can tune to is 503 kHz.

If we turn the value of the tuner capacitor to a value of 48.8 pF, the resonance frequency will be 1611 kHz.

Here in Europe 1611 kHz is the highest frequency on medium wave.

So, with this LC circuit we can tune over the entire MW band.

In practice both coil and detector diode will have a certain capacitance, so we must set the tuner capacitor to a lower value for tuning at 1611 kHz.

If the coil has too much capacity it is possible that we can't reach the highest frequency.

In this case we can add some space between the turns of the coil, this will reduce capacity.

$$R_{\text{shunt}} = 2 * \pi * 1 \text{ MHz} * \text{loaded } Q * L \quad \text{Eq. 8}$$

As an example, if we have a 240 uH coil and we want the loaded Q to be 20 at 1 MHz then the total shunt load should be 30,000 ohms. Assuming coil losses are small this means that the detector impedance should be 60,000 ohms and that the antenna impedance should be transformed (via a tap near the ground end of the coil) up to 60,000 ohms. This particular scenario is a practical one that can be built.

Concluding remarks

Although it is discussed in other chapters it should be mentioned here that we generally want to make the detector impedance as high as possible in order that we can use the highest inductance practical. This results in the maximum signal voltage applied to the detector thus lowering the losses in the detector circuit.

A significant factor to be aware of is stray capacitance across the inductor. This capacitance results from the natural physics of the winding (conductors separated by insulation). This stray capacitance is typically in the 10 to 50 pF range depending on how the inductor is wound and is in shunt with the tuning capacitance. The effect is to limit the upper frequency that the inductor can be tuned too. The effect is worse in large value inductors and that typically limits the maximum practical inductance to something less than 1 millihenry. There are some advanced winding methods that minimize stray capacitance but those are beyond the scope of this chapter.

A properly employed antenna tuner will do a lot of "heavy lifting" for you. First, it can make your antenna resonant at the frequency of interest, and bring up the signal level at the same time. Second, it will screen out a lot of unwanted stations, including those out of band ghosts. Third, it will transfer the signal efficiently to the main tuning and tank circuit, and do so such that you can vary the selectivity of your set as a bonus. This seems like a set of tall orders, but it isn't nearly as hard as it may seem. I will discuss mostly sets using air core solenoid tuning coils (that is, toilet paper rolls wrapped with a single layer of wire or the like), since that's what I usually use and have the most experience with. Before we start, let me say that an antenna tuner is not just another stage of passband filtering, such as the Miller 595 crystal set used. A key to a passband tuner design is when you see a two or more section variable capacitor, with one section in the gang working with one coil and the other section working with the second coil. Also let me add that an antenna tuner is essential for serious work.

Basic tuner : Wind a coil on a core the same diameter as your xtal set's main tuning coil. You may want to add about 30 to 50% more turns, but it should be at least as many turns as are on the main tuning coil. Put a tap at least every 10 turns

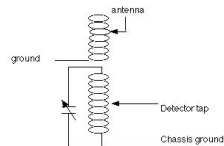

(every 5 is better). Put the two coil axes in line, and connect the end of the antenna coil that is closest to the xtal set to ground. Attach the antenna to taps on the antenna coil using an alligator clip until you get the best signal.

No direct connection to the xtal set is needed. You should find that you can separate the two coils by a distance of one coil diameter or more and get a good signal; in fact, moving them closer together may even make things worse. The closer the antenna is tapped to ground on the coil, the higher the frequency. You can leave the unused antenna coil turns "dangling", as it were, or attach the antenna to the other end and short the unused turns with the tap - both ways are acceptable. You should be able to notice a difference in signal strength of a station by moving just one or two taps along the coil. If you find that you never need to use more than half the coil for the best signal, even at the bottom of the AM band, don't worry; you may need them later. In this setup, you are essentially making the antenna appear the correct length, so you are in effect adding length to compensate for the short antenna. If you can't inductively couple the tuner to the set's tuning coil, you can attach your earth ground to the chassis ground of the set, and attach the ground end of the antenna coil to a suitable tap on the set's tank coil.

The Teenie Tuner: This is a variant of the basic tuner, using a coil wrapped around a ferrite core. Here's how to make one: Get a ferrite core of some sort, either a rod or a bar. Wrap some typing paper over it and glue the paper into a sleeve - put a spacer between the paper sleeve and the core while winding the coil so that the core will slide easily in and out of the coil after it is wound. Over the paper sleeve, wind a coil of some 50 to 90 turns of magnet wire in a single layer; no taps needed. Glue or tape the coil onto the sleeve. Now, mount the sleeve only on a support, such as a scrap of wood, or in line with the set's coil. Connect one end of the tuner coil to the antenna, the other to ground, and vary the tuning by sliding the ferrite rod in and out of the coil. You should get a range of

be used. The details would be a chapter in of itself but I can tell you that the practical absolute minimum inductance that is useful for a resonator in the AM broadcast band is around 40 microhenries as it is a challenge to obtain a high Q_u for inductances less than this in that frequency range. Thus, only the last column of Table 2 is useful.

Determination of maximum practical inductance: This calculation is done the same way as before except that the lowest value of loaded Q is used. That results in a higher inductance. Table 3 is a summary calculation. Again, the top two rows are for reference only.

Unloaded	1,000,000 Hz, resonant frequency					
	50,000 Hz, BW			20.0 Qloaded		
	Rdetector transformed across entire inductance					
	2K	5K	10K	20K	50K	100K
1,000,000	8.0E-6	19.9E-6	39.8E-6	79.6E-6	198.9E-6	397.9E-6
1,000	7.8E-6	19.5E-6	39.0E-6	78.0E-6	195.0E-6	389.9E-6
500	7.6E-6	19.1E-6	38.2E-6	76.4E-6	191.0E-6	382.0E-6
250	7.3E-6	18.3E-6	36.6E-6	73.2E-6	183.0E-6	366.1E-6
125	6.7E-6	16.7E-6	33.4E-6	66.8E-6	167.1E-6	334.2E-6

Table 2: Maximum inductance in Henries

Conclusions:

The conclusions from studying Tables 2 and 3 are that low values of inductance are needed for low impedance circuits and that high values of inductance are needed for high impedance circuits. Typical values of inductance used for the resonant circuit in crystal radios ranges from around 100 microhenries up to around 700 microhenries with more common values in the 200 to 400 microhenry range.

We can work Equation 7 backwards to determine a good value for the net shunt resistance across the coil at 1 MHz as follows.

two across the coil as R_{signal} . It was discussed previously that losses in the inductor can be represented by an effective resistance across the entire coil. We will refer to this loss resistance across the coil as R_{loss} . The parallel combination of R_{signal} and R_{loss} is the net resistance across a lossless inductor. We will refer to this net resistance as R_{shunt} . From Equation 5 we can write

$$X_L = R_{\text{shunt}} / \text{loaded } Q \quad \text{Eq. 6}$$

Thus, using a frequency of 1 MHz

$$L_{\text{min}} = X_L / (2 * \pi * 1 \text{ MHz}) = R_{\text{shunt}} / (2 * \pi * 1 \text{ MHz} * \text{loaded } Q) \quad \text{Eq. 7}$$

The detector impedance is typically in the 2,000 to 50,000 ohm range. With antenna matching the net resistance, R_{signal} , will be half this range as discussed above. Table 2 shows a summary calculation for the minimum value of inductance to use to achieve a loaded Q of 100 for various loads either directly or transformed across the coil. The Q of 1,000,000 row represents essentially infinite Q and the Q of 1,000 is not normally attainable and are shown for reference only.

1,000,000 Hz, resonant frequency						
10,000 Hz, BW		100.0 Qloaded				
Rdetector transformed across entire inductance						
Qunloaded	2K	5K	10K	20K	50K	100K
1,000,000	1.6E-6	4.0E-6	8.0E-6	15.9E-6	39.8E-6	79.6E-6
1,000	1.4E-6	3.6E-6	7.2E-6	14.3E-6	35.8E-6	71.6E-6
500	1.3E-6	3.2E-6	6.4E-6	12.7E-6	31.8E-6	63.7E-6
250	954.9E-9	2.4E-6	4.8E-6	9.5E-6	23.9E-6	47.7E-6
125	318.3E-9	795.8E-9	1.6E-6	3.2E-6	8.0E-6	15.9E-6

Table 2: Minimum Inductance in Henries

All of the inductances in Table 2 are small –some very small. But our target was the absolute minimum inductance that could

inductance of about 10:1 this way, effectively lengthening your antenna as the rod is pushed further into the coil. As with the basic tuner, you can set the tuning coil alongside the main coil, in line with it, or connect it's ground end to the antenna tap of the set. Just for grins, affix the teenie tuner to the back of your am superhet and see the improvement in your reception.

Series tuner : Here we add a variable capacitor, the same size as the one in your xtal set, in series with the antenna coil used in the basic tuner. Traditionally, you put it between the end of the antenna coil and the ground connection. Now you

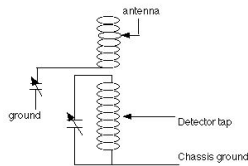

have two tuner adjustments to make (not counting distance of the antenna coil from the main tuning coil). For the first time, I recommend you get the set tuned to a moderately strong station, then put the tuner capacitor in the mid position, and then find a tap which allows you to hear the station. Then you can use the capacitor to bring in the station more sharply. You will probably find you need to use more turns of the coil than you did with the basic tuner, since the capacitor "shortens" the antenna. Ultimate signal strength may not show much improvement, but it should help selectivity. This setup is a favorite of the "pros". As before, the antenna and main tuning coils are in line. You should have to make fewer tap changes with a series tuner compared to the

basic tuner, since the capacitor does some of the tuning for you.

Parallel tuner : Use the same coil and capacitor as with the series tuner, except this time the capacitor is connected to both ends of the coil. One end of the coil, the one closest to the set, is connected to ground, and the antenna is connected to the coil tap that gives the best signal; incidentally, I have seen a few circuits where the antenna just connects to the other end of the coil from the ground - I don't recommend this, even though it works fairly well, sometimes, maybe, I think. Adjust the

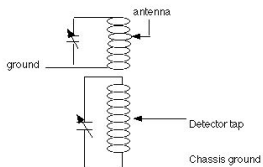

capacitor as needed to peak the signal. This setup is often used when the antenna is "very" short.

My recommendation to add turns to the antenna coil will sometimes let you use series tuning across the whole band. If your two coils are the same length, I think you will find that the series arrangement works best at the high end of the band, and the parallel arrangement is needed at the bottom; the longer your antenna, the lower in frequency you can use a series tuner. As with the series tuner, a parallel tuner gives you more selectivity than does the basic tuner.

Although there are an infinite number of combinations of inductance and capacitance that will resonate at a desired frequency there is only a limited range of practical values that can be used. An excellent question to ask is if there is an optimum inductance. If there is then that is what we will use. There is not a specific answer to that question other than there is an identifiable range of inductance that provides the best overall results. We will determine the extremes starting with the minimum practical value that will result in the highest allowable loaded Q followed by calculating the maximum practical value that will result in the lowest acceptable loaded Q. Any practical value of inductance between these two extremes can be used.

Determination of minimum practical inductance: As discussed previously, the highest loaded Q of resonance that is practical to use is such that the 3 dB bandwidth is about 10 kHz. This permits the full double sideband width to be detected. In extreme cases where we are willing to forfeit some audio fidelity to achieve better selectivity the bandwidth can be reduced to about 6 kHz –but we are not going to consider that case here. At 1 MHz (the rough center of the AM broadcast band), a 10 kHz bandwidth occurs with a loaded Q of 100. The antenna and detector circuits may be operating from taps on the inductor for the purpose of impedance matching (the method to design the taps is discussed in another chapter). The impedance at each tap can be transformed to an equivalent impedance across the entire coil. We will assume that the antenna circuit and detector circuit are impedance matched via this tapping process (this provides the much needed maximum power transfer from the antenna to the detector). Thus, for the impedance matched condition the antenna and detector impedance will transform to the identical impedance across the inductor. We will refer to the net parallel impedance of these

than about 50 so that the bandwidth is not too narrow. An excessively narrow bandwidth makes tuning very sharp and also distorts the audio. The bandwidth needs to be at least 10 kHz with 20 to 50 kHz being common. The following table illustrates the maximum, typical, and minimum loaded Q values to use across the AM broadcast band. Keep in mind that the unloaded Q of resonance should be significantly higher – preferably in the hundreds. The maximum Q value is for the minimum bandwidth of 10 kHz. The typical Q is a good value to try to achieve although realistically it is likely to be lower. The minimum Q has a fairly wide bandwidth and will not be able to separate stations well.

Frequency	QLmax	QLtyp	QLmin
0.5 MHz	50	25	10
1.0 MHz	100	50	20
1.7 MHz	170	85	34

Table 1: Practical ranges for Q of resonance in the AM broadcast band

The resonator has an effective resistance across it that represents coil losses. This resistance will be referred to as RQ. Ideally, RQ is infinity (i.e. no losses) but realistic values are typically in the many tens to hundreds of thousands of ohms. There are two loads on the resonator –one is effective source resistance, RS, of the matching network to the antenna and the other is the effective load resistance, RL, of the diode detector and audio transducer. For maximum power transfer from the antenna to the audio transducer the source and load resistances should be equal.

How to determine the required inductance

A broadband tuner : This is not a classic design, to my knowledge, and I stumbled on it by accident, but it does a lot of heavy lifting, and helped me well over the single digits in stations heard. I thought I was copying faithfully a design out of an ARRL handbook for dealing with random length antennas, but ended up with something a bit different, and won't try to analyze how it works, but here it is: Don't sweat the coil/capacitor specs; what you have in the series or parallel tuner will work fine. However, the connections shown going to receiver antenna and ground are actually connected to that coupling coil I mentioned up in quick fix number four. The tuner's orientation with respect to the set is not a factor, since the signal is transferred via the coupling coil. It will generally

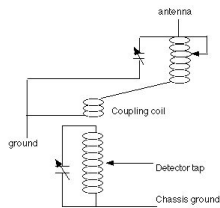

be closer to the main tuning coil than described in the three tuners above. I like this tuner arrangement for casual listening, as I don't have to play with it much over the band. Find the settings that

work best for you. It is a particularly good setup to use when you are finding out about a new xtal set, and don't want to have to mess with the tuner every hundred kHz or so, as you do with a more selective tuner, or don't want to "tailor" a tuner just for the new rig. This setup works well when you can't inductively couple the antenna tuner to the set. It also works without the coupling coil by connecting the end of the antenna coil to a low tap on the main tuning coil of the set.

All of the above tuning methods can be accomplished using a simple coil and capacitor arrangement, which I made up according to the schematic below:

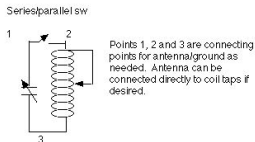

A selective tuner: Richard O'Neill used this tuner effectively in the 1999 DX contest (and everybody used it in the 2000 contest), and it is perhaps best known in connection with the Tuggle Circuit, which is described in detail in a couple of fine (and inexpensive) publications of the [The National Radio Club / DX Audio Service](#). Essentially, it is the same as a parallel tuner, except, you use a ganged capacitor, such as a dual 365 pF capacitor (some are still around), or even a "superhet" variable capacitor with an antenna and an oscillator section. One section (the larger one for a superhet capacitor) is in parallel with the antenna coil, and the other is between the parallel circuit and ground. I have tried this and it seems to work fine, and is very sharp. As before, try attaching the antenna to taps on the coil for best results; I find attaching it to the top of the coil works fine. Several popular crystal sets have used same double capacitor arrangement. If you don't use ganged capacitors, tuning this baby can be really tricky, since the two (make that three) capacitors interact a lot. When hooking this up to a ganged dual capacitor, the antenna and the top of the antenna coil are hooked to one stator. The bottom of

$$Q = \text{reactance} / R_{\text{series}}$$

$$\text{Eq. 6}$$

Inductors and capacitors have internal losses which appear as a resistance load either in series or shunt with the component. Losses in picofarad capacitors used at broadcast frequencies tend to be very small and thus these capacitors have a high Q (typically many hundreds) or as it is more commonly referred to in capacitors, low dissipation (the reciprocal of Q). Inductors have the dominant loss. This loss is commonly the series resistance of the wire (including skin-effect) but can also include losses in any magnetic medium used in the inductor. For good crystal radios we need inductors to have a Q in the hundreds.

Resonant circuits are not used in isolation. The antenna is coupled to the resonator as well as the diode detector. Both of these represent a resistive load which lowers the Q of resonance. This is referred to as the loaded Q. That may sound bad but it is actually fine. The loads represent power that we are interested in. We prefer that the resonator have low losses or high-Q. That permits the maximum transfer of power from the antenna to the detector.

Since any resistive load such as the antenna radiation resistance or the detector resistance lowers the net Q (i.e. Q_{loaded}) of resonance, it is important to start with a high unloaded Q known as Q_u. The Q_u of an LC resonant circuit is primarily determined by the Q of the inductor as its losses tend to dominate. Typical values for the inductor Q range from around 50 to over 500. If the tuning capacitor is of very good quality (i.e. air or silver mica insulation, etc.) then its Q will typically be in the 500 to over 2000 range. Although we like for the unloaded Q of the resonator to be as high as practical for low losses, it is desirable for the loaded Q to be no more

The required tuning range, C_{max} / C_{min} , of a variable capacitor can be determined using Equation 2 as follows

$$\frac{C_{max}}{C_{min}} = \frac{1}{(2 * \pi * F_{min})^2 * L} \cdot \frac{F_{max}^2}{1} = \frac{F_{max}^2}{(2 * \pi * F_{max})^2 * L} \quad \text{Eq. 3}$$

For the AM broadcast band F_{max} is generally 1.7 MHz and F_{min} is 0.54 MHz. Thus, the ratio of C_{max} to C_{min} should be around 10.

Tuning inductor

The classic ancient method of making a variable inductor was to provide a movable wiper to connect to individual turns of the winding. Modern methods use a movable ferrite rod to vary the inductance. Similarly to the development of Equation 3, the ratio of L_{max} to L_{min} is the square of the desired frequency ratio and works out to be around 10 for the AM broadcast band.

Discussion of Q

Q can be defined in several ways and each way is compatible with the others as shown below.

$$Q = \text{resonant frequency} / \text{bandwidth} \times 3 \text{ db} \quad \text{Eq. 4}$$

$$Q = R_{\text{shunt}} / \text{reactance} \quad \text{Eq. 5}$$

the coil goes to the rotor (frame), and the ground to the second stator. Note that with decent Q coils, you will experience some hand capacitance effects. I simply used some 9/32 " aluminum tubing on the 1/4 " capacitor shaft, then used about 2 inches of 1/4 " dowel rod as an extension, and put the tuning knob on the dowel; worked fine. Sometimes, when tuning the top of the band (higher frequencies), I can spread the tuner out a bit by making it a series tuner. All I have to do is disconnect the first stator from the top of the coil. Yeah, this means the ground is not attached to the rotor as in a proper series tuner, but it works fine, particularly if you have already done the hand capacitance elimination step.

As long as you have gone this far, why not try connecting the detector to the top of the detector coil instead of to a tap. Works pretty well with a crystal earplug, and cuts out the shortwave intruders. With magnetic phones, using an impedance matching transformer per Ben Tongue's page is rally the thing to do. However folks, with the tuner you

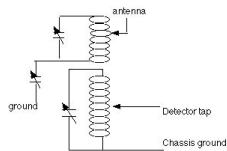

already have an additional filtering stage in operation, and can sacrifice a bit of selectivity with the high detector tap; anything to get rid of the intruders in a pinch, particularly in the

early evening when they can take over your set.

While I mentioned putting the two coils on the same axis, you can also place them side by side, as Mike Tuggle does

with his Lyonodyne #17 (getting 2500 mile contacts), using an antenna tuning coil wound with Litz wire on a ferrite rod; just make sure they are parallel for maximum coupling. You can vary the coupling by either separating them from each other or by rotating one of them from the parallel position, as is done with variocouplers. Minimum coupling occurs for a given distance when the axes of the two coils are perpendicular.

For you people using toroids in your xtal set, I have only to offer what you see in the "quick fixes". My tuners essentially rely on loose coupling to the main coil, and I really haven't played with the other type tuning coils enough. [Al Klase](#) uses toroids in his very fine crystal set, and you should look at his page for coupling to that. Also look at his work on XTAL Sets 102 for ideas.

In your quest for sensitivity and selectivity, you may now be ready to try a wave trap, sometimes known as a QRM coil, to get rid of offending, overbearing bandmaster stations. The premise is simple; trap the strong signal and it won't bury the weaker ones. While I can separate two local stations that are 40 kHz apart, with one of them at least 3 dB louder than the other one, I often can't eliminate the louder station entirely, and can often hear it in other parts of the dial except when I am between stations. Then there is the signal from the secret Radio Habana transmitting site, which pokes through at odd times. Crystal radios tend to go with the signal that is the loudest, hanging on until something better comes along. A decent wave trap just might be the answer. . One basic design is around a high resistance coil, 32 gage wire or so, in parallel with a variable capacitor, and a 15 turn link around the coil which connects antenna to set (or wherever you want to

Note that the Q=100 curve has a band-pass of 10 kHz which is about the minimum that can be used to recover the entire double-sideband signal.

Tuning capacitor

Generally, when the capacitor is variable, the inductor is fixed and visa-versa. Mechanical variable capacitors (often 10 –365 pF or similar) were very popular in older times but are more difficult to find in modern times. A modern substitute can be made using one or more rotary switches as will be illustrated later.

The well know equation for the resonant frequency of an inductor and capacitor is

$$F = \frac{1}{2 * \pi * \text{sqrt}(L * C)} \quad \text{Eq. 1}$$

where

F = resonant frequency in Hz

L = inductance in henries

C = capacitance in farads

For a given inductance the required value of capacitance can be determined from

$$C = \frac{1}{(2 * \pi * F)^2 * L} \quad \text{Eq. 2}$$

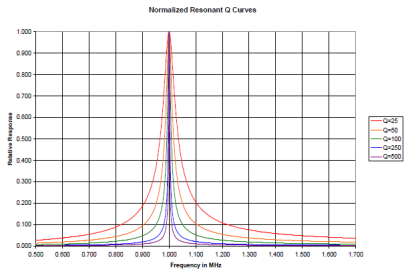

Figure 1: Normalized resonance curves at 1 MHz

Figure 2 shows a zoomed in version of Figure 1.

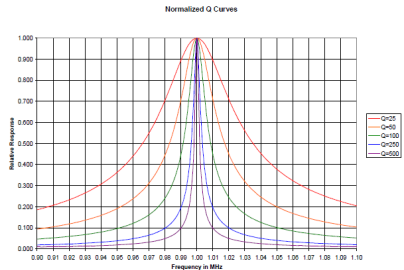

Figure 2: Normalized resonance curves at 1 MHz

try it. The idea is that the resonant LC circuit not only is set into motion by the offending signal but also dissipates it in the high resistance windings of the coil. The link lets the other signals bypass the trap with little loss. Here is a link to a nice short page on wave traps. <http://pages.ca.inter.net/~funk/trap.GIF> These traps, with no coupling coil, work best for out of band intruders when used as in-line traps in the antenna line, or when inductively coupled to your set's tank circuit. I think the one I use is better for in-line use, and you can find a description, picture, and discussion of it and trapping in general [here](#). I realize that a wave trap might not be considered technically a part of the antenna system, but as long as it is in front of the main tuning circuit, I will consider it so. Wave traps can be used as either rejectors, to block an offending station, or as acceptors, which can be sometimes used to boost a desired station or, more commonly, to add another stage of filtering to increase overall selectivity.

Antennas for the short waves, some notes and preliminary tests (a/o Nov 01):

When you go for the short wave bands, and I think you'll be pleasantly surprised when you do, you will find that even your 50 foot long antenna is more than a quarter wavelength long on even the 49 meter broadcast band. This is a bonus, but also calls for some different ways of holding your head on tuning the antenna to resonance and then coupling it to the detector circuit. If you're like me, you use some sort of coupling coil to the detector tank circuit, and a simple coupling coil will only make the antenna appear longer. My first attempts to couple the antenna to the set and tune it at the same

time were somewhat frustrating, especially since I was trying to tune from about 5.8 - 15 MHz. A combination of coils and capacitors that worked on one band did not on another. Then Steve Holden made this timely posting on the Crystal Set Radio Club forum, and I got a better appreciation of the problem:

In the October 1934 edition of Short Wave Craft, Editor Hugo Gernsback writes about Short Wave antennas on page 344. On page 345, fig. 6 shows a schematic of an antenna tuner that is a Coil in series with the antenna, with a parallel Variable Cap (C1); under the Coil is another Varicap (C) that goes to ground.

Gernsback writes, "In figure 6 we have endeavored to strike a happy medium, that is, an antenna that can be tuned and will respond to the SW broadcast bands, 19, 25, 31, 49 meters. The length of the antenna from A to B, that is the flat top and including what leadin may exist, should be 75'. The ground lead should be as short as possible, not over 4-5' long. With C, C1, and L it is possible to tune this antenna to any of the 4 bands mentioned. On some bands it will be a Hertzian and on others it will function as a Marconi. On the 49 meter band a Hz ant. will need to be 80' long. By setting C to a minimum the system becomes, in effect, not grounded. Therefore L and C1 can tune it up to an effective length of 80'. In the 31 meter band this antenna functions as a 3/4 wave Marconi. C should be adjusted to approximately half, and the tuning done with C1. In the 25 meter band, it is also a 3/4 wave marconi, and it is necessary that the effective length be reduced to 60'. This is accomplished by the adjustment of C with C1 set to minimum capacity. In the 19 meter band it is possible to make

RESONANT CIRCUIT

by Kenneth A. Kuhn

http://www.kennethkuhn.com/students/crystal_radios/resonant_circuit.pdf

The resonant circuit plays a very important role in a radio receiver. Its primary purpose is to be a tunable narrow band-pass filter for selecting a desired station while rejecting undesired stations. An important secondary purpose is to be a means for transforming the low impedance antenna up to the high impedance detector.

A resonant circuit is comprised of an inductor and a capacitor, one or both of which may be variable. Energy flows back and forth between the inductor and capacitor at the resonant frequency. Energy in the inductor is stored in a magnetic field and energy in the capacitor is stored in an electric field. If there were no losses, this cyclic process could continue forever. In reality there is some loss each time the energy moves. This loss is expressed as a resistance. A common term used to account for this loss is Q which is the inverse of the loss. Thus, a high-Q resonance has very low loss and the cyclic process can continue for many cycles. A common example is a bell which continues to ring long after being hit.

Figure 1 shows the frequency response of a resonant circuit at 1 MHz for a range of Q.

voltage across the LC circuit

The voltmeter measures the detected DC voltage

The load resistor is formed by resistor R parallel with the voltmeter with 10 M Ω input resistance

The value of capacitor C is: 100 nF

The RF signal is supplied by a DDS signal generator, the signal is via a coupling coil coupled to the LC circuit.

All measurements are done at a frequency of about 1500 kHz.

At 1500 kHz, the impedance of the unloaded detector unit is: 1.97 M Ω .

There are 4 (combinations of) diodes tested.

HSMS-282K Schottky diode (2 diodes in one case parallel)

HSMS-282K Schottky diode (1 diode)

5082-2835 Schottky diode (2 diodes parallel)

5082-2835 Schottky diode (1 diode)

the antenna function as a $\frac{1}{4}$ quarter wave Marconi. The necessary length here is 75 feet so we can use C for tuning and C1 should be set at minimum." In the next paragraph he talks about coil making, 20 turns DCC (double cotton covered) on a 1" diameter form. He recommends inductive coupling to the radio. From context I think the caps are standard MW units.

In other words, what Gernsback was saying was that I should use a Tuggle type tuner, but independently tune the two capacitors. Since I was already tuning through some 10 MHz of bandwidth with a 180 degree rotation of the dial, the thought of trying to get three capacitors to tune to the same frequency was somewhat daunting, particularly since my simple sets are typically calibrated by "feel". So, I started playing around a bit more, and finally (I think) came up with a coil/cap combination that gets me back to one knob antenna tuning. I used a coil of about 5 uH in parallel with the 160 pF section of one of the little polyfilm tuning capacitors, attached the antenna to one end of the tank circuit, and the ground to the 60 pF section of the capacitor. I got a dip using a grid dip oscillator across the tuning range of the detector tank circuit, and it seems to work pretty well with both my 50 foot and my 160 foot antennas. Now I am at least back to two handed tuning - hi.

Here is another approach I tried, and it works about as well (if not better), and I don't really know why. I make a tank circuit duplicating the tank in the detector circuit, and then attached just the antenna to the top of it. Darned if it didn't work well, and I was able to separate the two coils by as much as a couple or more coil diameters. Haven't tried it yet, but it might be that you can get the two circuits to track, and use a

ganged capacitor. Mike Tuggle gets his best results without a ground, so maybe I'm on to something here. Yeah, someone out there is chuckling as they read this, having known -this all along, but I'm the one with the web site, so I'll take the credit - hi.

Final warning! When you do anything to the antenna system, you can expect it to affect some other aspect of the crystal radio's tuning. When you are ready to start making adjustments, have a comfortable chair, a tall drink, maybe something to make notes with, and the time to be patient. And oh yeah, I didn't even mention the possibility of using different antennas, different grounds, loop antennas, no ground at all... and did I mention lightning arrestors?

If you noodle around on the web a bit, you will find some excellent antenna articles. I am just trying to get you started. As I said before, every antenna is a compromise - just try to get a setup that works for you, and then you can get back to building and testing your own crystal set creations.

A word or two about small loop antennas, portable antennas and the like: You will find at times references, plans and testimonials in praise of the small loop antennae. If you live near strong stations, they may work for you. Where I live, they are almost useless, and do require a ground. I personally believe that if you are going after the distant stations with a loop you will be very disappointed. These are specialty antennas and have limited value - but where they do work, they get high marks. As an aside, I suspect that if you can't get at least 30 feet of honest antenna out the window, you might

EXPERIMENTS WITH A DETECTOR UNIT

Dick Kleijer crystal-radio.eu

<http://www.crystal-radio.eu/enantunitest1.htm>

On this page measurements are described on my [detector unit 1](#).

In this detector unit is as diode used the HSMS-282K (2 diodes parallel), and the load resistance by [transformer unit 1](#) is 1.6 M Ω .

For the choice of diode and load resistance I assumed that maximum sensitivity would occur if load resistance and diode resistance were about equal to the impedance of the unloaded LC circuit (this assumption is however not correct).

Via some experiments I will now determine if the sensitivity and selectivity can be improved by the use of another detector diode and/or another load resistor.

Also frequency shift of the detector circuit is measured as a function of the voltage across the circuit.

Test setup used for the measurements on this page.

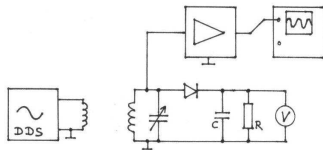

The oscilloscope measures via the [measuring amplifier](#) the

try a large diameter loop antenna instead. If you are new to this business, start at the top with an honest antenna (please try for at least 50 feet out the window), and then, when you start getting experience, and have a set you know works, try what you like. Trying to hook up a first crystal set with a small loop is an invitation to frustration.

Made with a resistor of 50 Ohm, a coil of 20 uH, and a capacitor of 200 pF. The 50 Ohm output resistance of the signal generator is in parallel with the 50 Ohm resistor.

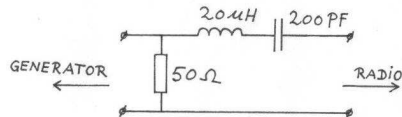

The dummy antenna makes the receiver input is driven with a impedance of 25 Ohm in series with 20 uH in series with 200 pF. This is about the impedance of a average longwire antenna. With the dummy antenna connected to the generator (but without the receiver connected), the output voltage of the generator is adjusted to 50 mV peak-peak.

Now with various settings of C1, the frequency range of the circuit, the voltage across coil L1, and the Q (across coil L1) are measured.

The measured voltages are Volt peak-peak.

The frequency range can be slightly influenced by the measuring amplifier which was connected across coil L1.

The circuit L1,C2 has a high impedance (e.g. 1 M.Ω). But the antenna has a low impedance (e.g. 10 Ω), tuning capacitor C1 forms a impedance match between this high and low impedance.

With a certain value of C1, there will be maximum power transfer from antenna to the circuit L1,C2. Then there is maximum voltage across the coil L1, and maximum sensitivity of the receiver. At low frequencies we must for instance adjust C1 to 100 pF, and at high frequencies to 20 pF, but these values are depending on the (length of) antenna we connect to it. For the circuit Q however, the lower the value of C1, the higher the Q. More information about this, you will find here.

Coil L1 is wound with litzwire 660x 0.04mm (660/46 AWG), on a polypropylene former. This coil is described here as coil L12, only the outermost winding is removed to reduce inductance a little bit. This reduced the total wirelength from 15 to 14.5 meters.

The frame of this antenna unit is made of 8mm polyethylene sheet.

Tuning capacitor C2 is driven via a 1:5 vernier drive, so we can tune it very accurately. Tuning capacitor C1 has no vernier drive.

Experiments:

During the measurements the antenna unit is connected to the signal generator via a dummy antenna.

The dummy antenna.

CRYSTAL RADIO DXing

Steve McDonald

<http://members.shaw.ca/ve7sl/crystal.html>

If you are anything like most radio 'nuts', you probably had a crystal set when you were a kid. Thinking back to those good old days, I recall that I could only hear two local stations on my crystal radio. I had always believed that you just couldn't hear very far on a crystal set.....until I ran across this picture!



It was a picture of Al Klase's wonderful "Crystal Radio DX Contest" station! I was amazed to learn that it was even possible to hear 'DX' on a crystal radio and, apparently, there was a large group of very active crystal radio DXers. I was hooked on learning more about this fascinating possibility!

PUSHING THE BOUNDARIES... With some further investigation I turned up the 2001 contest winner, Mike Tuggle in Hawaii. Mike had logged 63 stations and Cuba, all on the AM broadcast band! It turned out that Mike, after years of experimenting, had developed an extremely efficient DX set, which he called the "LYONODYNE 17".

Mike's elegant set is not only a work of art but also 'state of the art', using large diameter basketwound Litz-wire coils and high quality, low loss ceramic tuning capacitors. To be 'legal' in the crystal set community, the radio must be completely "passive", meaning no amplification of any form is allowed. The only power used must come from the antenna, making these DX Contest results even more amazing!

LOCATION! LOCATION!... Crystal-set DXers are up against two problems:

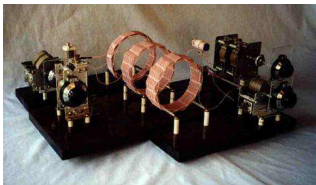

SELECTIVITY versus **SENSITIVITY**. If you live in a city or near a large city that has several 'blowtorch' AM signals, your main focus will be on separating signals so that the weaker DX can be heard between the blowtorches. On the other hand, if you live in the country, you don't have to worry so much about

EXPERIMENTS WITH AN ANTENNA TUNER UNIT

Dick Kleijer crystal-radio.eu

<http://www.crystal-radio.eu/enantunitest1.htm>

Here some measurements done with my "[antenna unit1](#)".

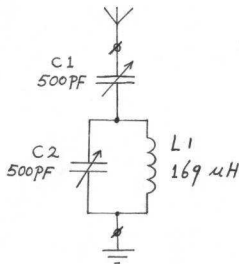

Schematic of the antenna unit 1.

The antenna unit has a tuned circuit L1, C2.

If we only look at L1 and C2, then the tuning range is 550 - 2184 kHz. But if we also connect the antenna and earth, the frequency of the circuit will decrease, so we can also receive the lowest mediumwave frequency of 530 kHz.

Variable capacitor C1 and the antenna and earth are also a part of the tuned circuit, but the antenna and earth also give reduction of circuit Q.

separating strong locals; you can run things 'wide-open' enabling you to log some of the weaker DX signals. Living away from the city certainly makes life simpler for crystal radio DXing but don't despair if you are a city-dweller. One of the DX Contest winners lived in San Jose and still managed to log plenty of DX!

QUICKY BASICS

The diagram shows a simple basic crystal radio. In the city, with a good antenna, such a set will hear plenty of locals but it is unlikely to hear any DX. Take it out to the campground for the weekend however and even a simple set like this is capable of logging DX. Since most of us live in or near the city, we need to look at ways of transforming the basic set

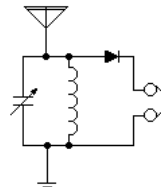

Basic Crystal Radio

into a DX machine!

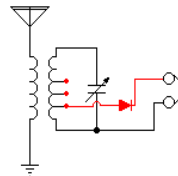

Loose-coupled Antenna Circuit

In order to separate the strong locals, the tuned circuit (L-C) must have as high a 'Q' as possible. Placing the diode and headphone load at the top of the circuit will result in strong signals

but poor selectivity. The impedance of the headphones will load down the tuned circuit, lowering its 'Q'. The result is very poor selectivity. Tapping the diode/headphone load at a lower point in the tuned circuit results in less 'Q-lowering' of the circuit. The result is a higher degree of selectivity. You don't, however, get a free ride! The higher selectivity diode tap point results in less overall voltage being fed to the headphones. Signals are weaker but easier to separate! The challenge of building an efficient tuner is to find the right balance between selectivity and sensitivity!

There are a few more improvements that will help the 'basic set'. More sensitivity as well as more selectivity can be realized in the antenna circuit. A separate antenna coupling coil that will couple the antenna into the main tuning coil will result in a further overall improvement. If the position of the antenna coil can be adjusted in relation to the main tuning (detector) coil, a degree of coupling can be reached that offers a good balance point between adequate sensitivity and improved selectivity. Often the antenna coil and the detector coils are mounted on a long rod or dowel that allows easy adjustment of the 'loose-coupling' circuits. Also note that improved detector tuning can be achieved by optimizing the diode 'tap' location on the main tuning coil.

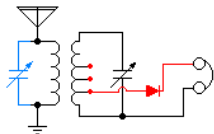

Parallel-tuned Antenna Coupler

Further improvements in both sensitivity and selectivity can be achieved by actually tuning

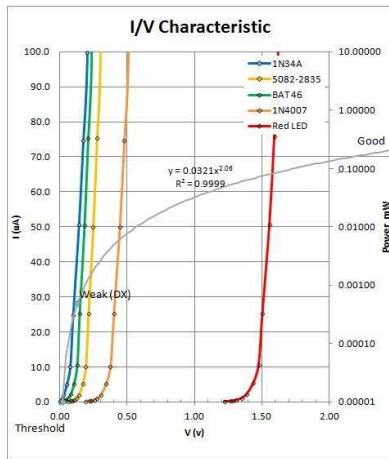

This plot at left takes some actual diode I/V measurements rather than the models presented below and plots them along with the above RF voltage across the LC circuit versus RF power in mW. Here one sees that pushing for very very low V_f (via high I_s / low n combinations) pushes the limit of detectable signal power from the antenna. At such minute power levels I imagine the reverse leakage current becomes significant and probably offsets the low operating point gains sought.

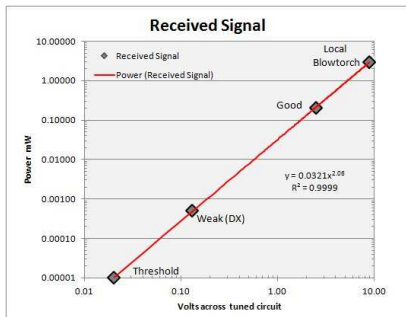

The above is an interesting plot taken from the text discussion in "Crystal Set Analysis" by Berthold Bosch. It presents received signal strength across the tuned circuit for various scenarios from threshold audibility to local blowtorch. This plot should be considered a single example specific to his location and antenna/ground system. In the text he describes his antenna as an inverted L 43m long (140') and 10m high (32'), an excellent antenna most of us do not have the real estate to erect, but offsetting this is a poor ground with $R_g = 210\text{ohms}$. Given the offsetting conditions I would imagine this is a good generic example of what received signal voltage and power levels presented across the LC circuit to the diode are likely to be. Bosch cited 40nV as the threshold of audible detectability (impedance matched conditions with 16kohm RF impedance / 4kohm DC phones) and for this plot I pushed it back to 20nV as it gave a superior regression fit.

the antenna system to resonance. Your type of antenna system as well as the part of the AM band that you are tuning will determine which system works best. The series-tuned antenna coupler is best suited for tuning large antennas, especially

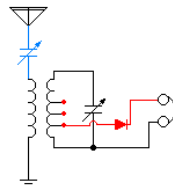

Series-tuned Antenna Coupler

those with large horizontal runs ("top hats"). The parallel-tuned antenna coupler is better suited for tuning shorter antennas, such as vertical wires, masts or whips - those without top hats. A series of test clips or a simple switching system can be used experimentally to determine what works best for you. *Making this effort is important as it goes a long way towards avoiding initial disappointment with the crystal set's performance.* Such a system as this is called a 'double-tuned' set. With care and attention to construction, such systems are capable of hearing DX signals.

Adding a tuning capacitor in series with the antenna permits a

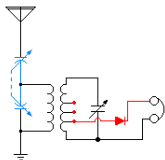

Enhanced Parallel-tuned Coupler

capacitor can be used as shown here. The added variable capacitor can be placed instead in the ground leg. This 'enhanced parallel-tuned' coupler can be very effective in peaking up desired signals while knocking down nearby interference. I have found the use of a tapped coil in this circuit to be very beneficial in achieving optimal Q for the portion of

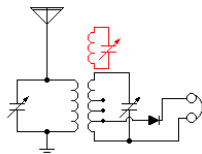

Loose-coupled Wavetrapp

(if not several) local 'pest' signals. Further gains in selectivity can be had by the addition of another tuned circuit, called a 'wavetrapp'. By coupling this circuit to the detector coil, this

long antenna to be tuned very effectively by a parallel-tuned antenna coupler. In fact, this is the method-of-choice for many crystal set listeners. To avoid the complication of an extra tuning knob, a single-knob, two-gang variable

band being tuned. One might even decide on using separate 'high-band' and 'low-band' coils for this circuit.

Although you may now be able to hear some DX, chances are you are still bothered by at least one

Additionally I have plotted RF signal R_s as orange circles from published coil unloaded Q (see my section on Coil Q). To convert from Q_u to Q_l I have made the assumption that loaded Q is about 1/5 unloaded Q for low-end sets while in performance sets it may approach 1/2.5 the unloaded Q. This is only an estimate then, but starting from actual data. To make the conversion to R_s I simply plugged the data into the standard equation $R = 2\pi f L Q$ using a scaling factor to divide down Q_u to Q_l from high Q (1400/2.5) to low Q (100/5). This provides a nice visual display of the expected range for R_s in many crystal sets. I plot the R_s against the value of Q_l used. Note that these data are for the case at about 1MHz and inductances between 200 and 300uH, as published.

Matching the diode to the tank is a matter of finding a diode with both sensitive qualities (low n) and an R_d close to the R_s presented to the diode (as per Ben Tongue's suggestions for Peak and Square Law detection). Those diodes with I_s 's in the 100 - 250 nA (100-280 kohm for $n=1.1$) or so range have the possibility to match while connected to the top of the tank coil without the use of Q-lowering taps, while untapped matching to high-end high-performance big-Litz baskets will require diodes with I_s 's in the 35 - 60 nA (500-800 kohm for $n=1.1$) range. Most "typical" germanium diodes have high I_s values (>500, >60kohm) and will require a tap. Diodes such as FO-215, BAT 46, 1N60 and GAZ51 can be matched to many tanks without taps. For tanks with high quality Litz coils one will be using HP 5082-2835 or 1SS98 diodes, generally 3 to 4 in parallel to lower the R_d to the desired range. (Curiously, I have not found any diodes with R_d values in the 300 to 4500 kohm range.) Note that both resistance and impedance are frequency-specific so a match at one frequency will not remain matched across the broadcast band.

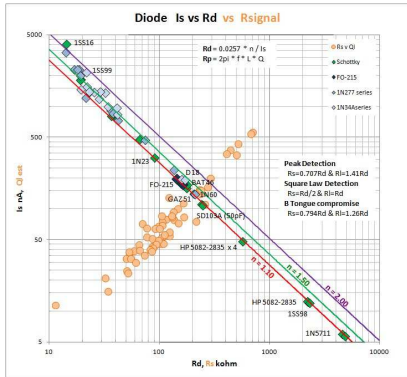

The plot above shows the relationship between diode I_s and R_d . R_d is calculated via the equation $R_d = VT * n / I_s$ where VT is the thermal voltage = $k * T / q = 0.0257V$ at room temperature and I_s and n are from the measured diodes. k is Boltzmann's constant = $1.38E-23$ J/K and q is the electron charge = $1.609E-19$ coulombs. On such a plot I can show lines of constant n , and plot the values for individual diodes for which I have spent considerable effort to determine the parameters I_s , n and R_d (where I_s is the diode saturation current, n is the ideality factor, and R_d is the diode resistance). On the plot it should be evident how changes in n or I_s impact a diodes' R_d .

circuit can be tuned to the same frequency of the pest signal, absorbing much of its signal-killing strength at the detector, while not adversely affecting the strength of wanted signals. More than one wavetraps may be employed to tackle more than one pest signal. With a high Q wavetraps, very loose coupling is usually best.

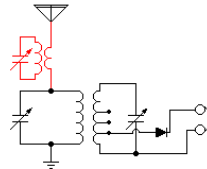

In-line Wavetraps

Another method that some find successful is the use of an 'in-line' wavetraps in the antenna circuit. The smaller secondary winding can be wound either on top of the primary or on one end. One or two in-line wavetraps can often be used to effectively knockdown the strong pest signals.

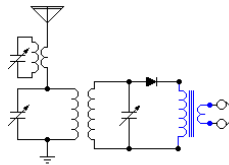

Impedance-matched Output

Another important improvement can be made in the headphone circuit. If you are using the old standard style of headphones (Brush, Baldwin etc) they must be high impedance phones. The modern low-impedance 'walkman' style phones will load-down the detector circuit too much, seriously degrading selectivity and signal strength. Even high impedance phones will cause unwanted loading of the detector circuit. Using a

low-loss audio transformer with a very high impedance primary between the phones and the detector will reduce the problem and often great gains in selectivity can be achieved. Look for a high quality audio transformer with a primary impedance of at least 100K ohms and a secondary to match your phones. Try to avoid the small printed circuit transformers used in transistor radios - this is a case of the bigger, the better.

One of the greatest improvements made on my own DX set



was changing from a pair of vintage high-quality Baldwin phones to a pair of headphones made from an old Navy 'sound-powered' handset. Most crystal radio DXers are utilizing this style of headphone. They are extremely sensitive! Old handsets are always available on e-Bay and can often be had at a bargain price. Often the earpiece transducer as well as the microphone element are identical and a single handset will yield a nice set of phones. The elements can be removed and placed inside an old set of headphone covers or hearing protectors. I think that going 'sound-powered' was the best

single improvement that I was able to make when my DX set was evolving

Why know the values of I_s , n , and R_d of your diodes?:

by Kevin Smith

<http://www.lessmiths.com/~kjsmith/crystal/deyeball.shtml>

I have been attempting to get a handle on the main diode parameters I_s , n , and R_d and how they impact the operation of a crystal radio. My method of choice is to use a graphical approach, plotting charts where variations between plotted parameters become apparent and easy to visualize. I have developed an interesting chart from the measurements above that compares many diodes with respect to I_s , n , and R_d , and to understand how this fits into a matching situation with a fuzzy indication of typical tank impedance limits.

Ultimately one seeks a diode with an R_d that matches with and conjugate to the impedance it sees from the tank (+antenna). In the following discussions I will start with the cross-plot of I_s to R_d and then proceed to a look at how received RF power plays a part in the selection and why low I_s and n are desired.

OA81 (germanium)	0.0225	800	34
OA95 #1 (germanium)	0.0272	600	45
OA95 #2	0.0221	821	33
OA95 #3	0.0271	604	45
OA95 #4	0.0304	502	54
AA116 (germanium)	0.0441	256	106
AA119 #1 (germanium)	0.0320	461	59
AA119 #2	0.0363	370	73
AA119 #3	0.0428	272	100

The HSMS282K is the same as the HSMS2820, only the HSMS282K has 2 equal diodes in one package.

The I_s value of the HSMS282K, the HSMS286K and the 5082-2835 is lower than the value in the datasheet, this has also been noticed by other people.

Ben Tongue wrote me, that the I_s value of the 5082-2835 has been reduced over the years by the manufacturer.

Also temperature has big influence, I measured at 18 °C, in datasheets the I_s value is given at 25 °C.

A increase from 18 °C to 25 °C will increase the I_s by 60 %.

BUILDING YOUR DX SET... Start by thoroughly checking out the many links shown at the bottom of the page. There is a huge amount of good information available on the web. The 'Yahoo Crystal Radio Group' as well as the 'Rap'n Tap' group both provide an interactive forum for asking questions. I would suggest

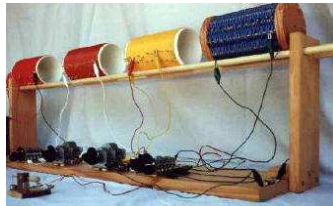

that you consider an experimental loose-coupled test bench.

This will allow you to easily make coil changes and adjust coupling between circuits. A fine example of a loose-coupled set is shown below. It was built by Larry Pizzella in San Jose and



was used by him to win the 1999 DX Contest!

Although the loose-coupled coil rack is not visible in the photo, my own DX set was built along these same principles.

Many different coil styles, wire diameters and antenna tuning circuits were tried over the space of several months.

This is the schematic diagram of the final arrangement used in my 2002 DX Contest set.

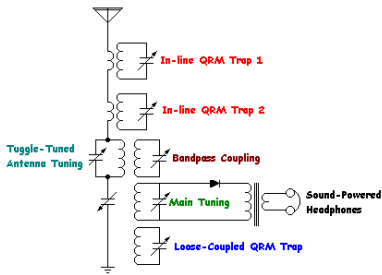

VE7SL - High-Performance DX Crystal Tuner

This is a 'triple-tuned' arrangement. There are vernier reduction drives on all tuning capacitors as tuning is very sharp on all circuits. Because of the great abundance of 'blowtorch' signals

More information about measuring the I_s you can find on the website of Ben Tongue, in his articles number 4 and 16.

I measured the I_s value of several diodes, and calculated the diode resistance R_D .

Also some European germanium types are measured.

Several diodes are measured of the type OA95 and AA119

Diode	V_D (Volt) at 1 μA	I_s (nA)	R_D (k Ω).
HSMS282K	0.1341	7.9	3428
HSMS282K 2 parallel	0.118	14.5	1867
HSMS286K (1 diode)	0.1116	18.3	1479
5082-2800	0.1871	1.14	23756
5082-2835	0.1464	5.04	5373
5082-2835 2 parallel	0.1289	9.5	2850
BAT 82	0.136	7.3	3710
BAT 85	0.0686	90.8	298

Measure the voltage across the diode (VD).

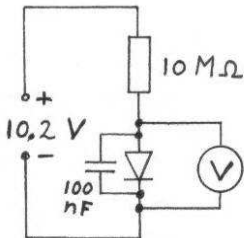

Circuit diagram for measuring the I_s value of a diode.

The voltage across the diode is about 0.2 Volt.

The voltage across the resistor is about 10 Volts, so the current is about $1 \mu\text{A}$.

The voltmeter must have a resistance of at least $10 \text{ M}\Omega$.

The 100 nF capacitor reduces the influence of radio signals and hum on the measurement.

Calculate I_s with the formula:

formula 3: $I_s = I_D / (e^{(V_D / (0.0257x_n))} - 1)$

I_s = saturation current of the diode in nA

I_D = current through the diode in nA, ($1 \mu\text{A} = 1000 \text{ nA}$)

e = base of the natural logarithms, this is about 2.718

\wedge = raise to the power of

V_D = voltage across the diode in Volt

n = ideality factor of the diode, if you don't know this value,

take for instance: $n = 1.08$

within 15 miles of my location (seven 50 KW locals) heavy trapping of pests is required. Both sensitivity and selectivity are good; on evenings of good propagation, signals from Alberta and California can become 'pests' in themselves! Both in-line traps and loose-coupled traps have proven to be very effective.

Not visible in the photo are the in-line wavetraps shown here. Calibrated dials help to quickly zero in on pest frequencies.

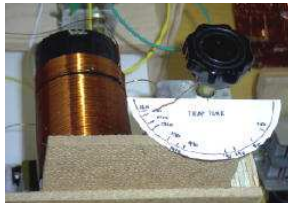

During the DX Contest 80 different stations were logged on the AM band, the furthest DX catch being WOAI in San Antonio, Texas. U.S. stations in WA, OR, ID, CA, UT, NV, MT and CO as well as Canadians in BC, AB, and SK were heard. Nine 1 KW stations along the west coast were logged as was the little 500 watter CKBX in 100 Mile House, B.C. As well as the DX set performed however, there was still much room for improvement!

BUILDING HINTS

1. Avoid winding coils on wood or cardboard forms. These materials, even when sealed, will absorb 'Q -killing' moisture and impair both selectivity and sensitivity. Use either styrene sewer pipe couplers, thin-walled black ABS plumbing pipe or white PVC tubing. For really high-Q coils, experiment with 'basket-weave' or 'rook' style windings.

2. Avoid small gauge wire for coils. Large diameter coils made of solid wire (#12-#18) are easy to wind. Try to space the coil winding so that each turn is at least one wire-diameter away from its neighbor. Stay away from taps if possible. Taps can quickly rob 'Q' from a coil.

3. Make your coils big! No smaller than four inches in diameter is a good starting point.

4. Use the best quality tuning capacitors that you can find. The ones with ceramic insulation are best. Try to avoid mounting them directly against moisture absorbing surfaces, such as wood. Insulate them with ceramic or plexi spacers. Use insulated shaft extensions to avoid hand-capacitance effects.

5. Devise a method of comparing different diodes. A switching arrangement that will accommodate more than one diode will allow some real-time 'A-B' diode comparisons. Test your diodes on a DX signal as a diode that produces the best signal on a strong local may not be the best one for hearing weak DX. Most older 1N34 diodes appear to be hotter than those manufactured today. Consider the use of Schottky diodes that

T = diode temperature
^ = raise to the power of

Ideality factor n

The ideality factor n of a diode indicates how good the diode performs with regard to an ideal diode.

A (not existing) ideal diode has a value of n=1.

At low input signals, the maximum available detected output power is proportional to 1/n.

So doubling the n will halve the output power (this only applies at weak signals).

Diode capacitance

Between the two connections of the diode there will be a certain capacitance (capacitor value), when this capacitance is fairly high (e.g. 10 pF) the tuning range at high frequencies is limited.

At increasing reverse voltage across the diode the capacitance will reduce, also the detected voltage in a crystal receiver is such a reverse voltage.

Through this, the frequency of the circuit can shift upwards when receiving strong signals.

On the next page: experiments with a detector unit you find in table 3 a measurement about the frequency shift.

Measuring the I_s value of a diode.

We can measure the I_s value of a diode as follows:

Send a small current through the diode, the value of this current (I_D) must be about 1 μ A.

With 3 diodes parallel, the value of RD shall be divided by 3 etc..

Diode resistance when using bias current.

We can decrease the value of RD by sending a small DC bias current (e.g. 0.1 uA) in forward direction through the diode. The higher the bias current, the lower RD will be.

With the following formula we can calculate the diode resistance RD, when we make use of a DC bias current.

Formula 2: $RD = 0.000086171 \times n \times TK / (Ib + Is)$

RD= diode resistance at certain DC bias current Ib (unit: Ohm)

n= ideality factor of the diode

TK = Temperature in Kelvin (= temperature in °C + 273)

Ib= DC bias current through the diode in A

Is =saturation current of the diode in A

A diode with a certain RD value at a certain bias current, gives the same receiving performance as a diode without bias current with the same RD.

Influence of temperature on "saturation current: Is"

The saturation current (Is-value) is strongly depending on temperature.

A temperature increase of 1 °C will increase the Is value by about 7 %.

In datasheets, the Is value is most times given at 25 °C.

If the diode temperature is not 25 °C, but another value "T", then we must multiply Is with a factor $1.07^{(T-25)}$.

have proven to be extremely sensitive when used in high-Q systems.

6. Don't wait too long before considering sound-powered phones. They are a must if you want to hear the weak ones. Watch e-Bay for some good bargains.

7. Use vernier dials/drives on all controls as the high-Q circuits often tune very sharply. Detector tuning and antenna tuners should have a logging scale so that tuning is repeatable.

8. Get your antenna as high as possible. If it can't be very long, then give it lots of top-loading as shown below.

9. Pay attention to your ground system. Buried wires acting as a ground counterpoise work well. Tie into the copper waterpipe system if possible.

10. Keep notes on your experiments.

11. Don't give up! Eventually you will break through and hear DX. On nights of good propagation the band will come alive with signals.

The values of n and I_s can (sometimes) be found in the diode datasheet.

In the following table some types of schottky diodes, with the values for n , I_s and R_d , the maximum reverse voltage and the diode capacitance at zero voltage.

type diode	n	I_s at 25 °C	R_D at 25 °C	maximum reverse voltage	capacitance	
5082-2835	1.08	22 nA	1260 k Ω	8 Volt	1 pF	datasheet
BAT85	?	?	\pm 200 k Ω ??	30 Volt	10 pF	datasheet
HSMS 2820	1.08	22 nA	1260 k Ω	15 Volt	1 pF	datasheet
HSMS 2850	1.06	3000 nA	9.07 k Ω	2 Volt	0.3 pF	datasheet
HSMS 2860	1.10	38 nA	743 k Ω	4 Volt	0.3 pF	datasheet

To decrease the value R_D , we can connect more diodes in parallel, with two the same diodes parallel the value of R_D shall halve.

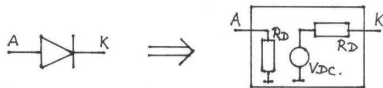

Equivalent circuit of a diode at low input voltages

Via this link you find a measurement on several schottky diodes, which shows detection in the square law region takes place at input voltages below 200 mVpp.

Diode resistance R_D .

At zero voltage, diodes have a certain resistance.

This resistance at zero Volt we call R_D .

The lower the reverse leaking current of the diode, the higher resistance R_D .

When detecting small signals (in the square law region) the input of the diode also behaves like a resistor with value R_D .

But how do we know the R_D of a diode?

We can calculate it with the formula:

formula 1: $R_D = 0.000086171 \times n \times TK / I_s$

R_D = diode resistance at zero Volt (unit: Ohm)

n = ideality factor, the lower this factor the better, between 1.0 and 1.1 is a very good value.

TK = temperature in Kelvin (= temperature in $^{\circ}C + 273$)

I_s = saturation current (unit: A)

\times = multiply

THE CRYSTAL RADIO SET REVISITED

No Author, Smith-Kettlewell

<http://www.ski.org/Rehab/sktf/vol11no4Fall1990.html>

Abstract

Although this is an article presenting variations on designs of crystal radio sets, I tried to put enough theory in here for universal appeal. For example, impedance matching with transformers is discussed, a formula for calculating single-layer air-core inductors is given, and the "Daniell cell" (a voltaic cell made from a lemon) is also described.

Introduction

[The editor would like to acknowledge the writings and accomplishments of Mr. Joseph Amoros of Richmond, Virginia, who published crystal radio circuits between 1941 and 1953. He sold my father boxes of crystal-set parts when he closed his mail-order business in 1957, and he brought us much joy in experimentation.]

A Bill Gerrish passion is the "crystal set"--the simplest possible radio receiver. It got its name for its crystal detector. Once upon a time, this detector was made by scratching around on a small chip of galena with a rusty wire, hoping to find the happy accident of oxides that would rectify the radio signal and present the amplitude envelope to your headphones.

Actually, various metallic sulfides were used as "crystals." "Galena," lead sulfide or PbS , is the most common ore of lead, and this was often used. "Iron pyrites, iron disulfide or FeS_2

(sometimes called "fool's gold") was another ore used. Even Carborundum (a trade name for silicon carbide, SiC) was sometimes employed as the crystal. A blue-steel wire with a sharpened point was the "cat's whisker."

Modern crystal sets use germanium PN-junction diodes for their detectors. These are better diodes than those created from oxides, and they are a lot less fuss.

The purist's crystal radio set is a passive receiver; the power that "runs" it is what you steal from the radio station you are listening to. I leave them connected for years at a time.

With my father's help, I built my first one at age six, and I have hobbled around with them ever since--finding new and better coils now and then, or just putting them in differently shaped containers for the lark of it. The constant faint chatter from earphones hanging on a hook (in my lab upstairs and in the garage) is as friendly as the sound of a familiar clock to me.

Why do I entertain this frivolous pursuit? It's culturally enriching; it causes me to listen to talk shows, music, and yammering advertisers that I would normally leave the room to avoid. I suppose it brings back memories of a kind father revealing his best "shop tricks" to an impatient child who was barely listening.

How Do They Work?

Well, a big long antenna gets in the way of all those waves, and a tuned circuit (a coil and capacitor) resonates to absorb the maximum amount of energy from the station you want--barely attenuating the others. Then comes the heart of the set, the detector.

The power losses in the diode are in this region very low compared to the rectified power.

Situation 2: Rectifying in the square law region

If the input voltage is low, lower than the voltage drop of the diode (at 1 mA) then the situation is completely different.

The input of the diode behaves for the RF signal like a resistor with value R_D .

The output of the diode behaves like a DC voltage source in series with a resistor, the value of this resistor is also equal to R_D .

The value of the DC voltage source is square law related to the amplitude of the RF input signal.

So double input voltage, gives 4 times as much detected DC voltage at the output

In the square law region the output voltage of the diode will be much lower than the input voltage, the diode gives much power loss between input and output.

The lower the input voltage, the higher the losses.

The higher the input voltage, the lower the diode losses.

When further increasing the diode input voltage, we gradually come into the linear detection region.

When receiving weak stations, detection takes place in the square law region.

Between the linear and square law region, there is a region not linear, and not square law but somewhere in between.

This region is not discussed here.

best test several germanium diodes in our receiver and then choose the best. The diode resistance R_D of germanium diodes is most times rather low, and only useable in crystal receivers with a low Q (low sensitivity and low selectivity). For high performance receivers, we can better use a suitable schottky diode.

Schottky diodes have a voltage drop of about 0.25 Volt. The differences in properties between two diodes of the same type are often small. Schottky diodes with the correct resistance R_D are very useable in high quality crystal receivers.

The given voltage drop is normally measured at a forward current of about 1 mA. Also if we measure the voltage drop of a diode with a multimeter, the test current shall be about 1 mA. But also below this voltage drop the diode can conduct current, and can rectify a RF (radio frequency) signal. Only the current through the diode is then much smaller. When receiving very weak stations, the current through the diode can be e.g. only 10 nA. At such a low current, the voltage drop of the diode is also much lower than at 1 mA.

Detected voltage as function of the input voltage. If we rectify a RF signal with a diode we can distinguish two situations.

Situation 1: Rectifying in the linear region

If the input voltage is high enough (well above the voltage drop of the diode at 1 mA), the output voltage of the diode will be about proportional to the input voltage.

So double input voltage, gives about double output voltage.

The output voltage is almost equal to the peak value of the input voltage.

By itself, a radio signal has no audible component. Stations suitable for this kind of detection have the amplitude of their radio-frequency (RF) signal "modulated" (the power made greater or lesser) by the "intelligence?". (Intelligence on AM radio? Nah!) In order to hear these fluctuations in amplitude, you have to strip away the radio-frequency "carrier" and detect the "envelope" of the amplitude variations.

The diode detector is a rectifier-filter system that feeds the earphones the instantaneous peak value of the RF signal. This peak value is the "amplitude" of the signal, and when you retrieve that information, you get amplitude variations that are the modulating audio.

The rectifier, conducting only in one direction, charges a filter capacitor which then follows the peaks of the RF signal. The filter capacitor is the 0.005uF unit found throughout these circuits, and the diode is the "crystal detector."

Antenna Requirements

The crystal set needs a long antenna and some sort of ground return. A water main is usually the best ground, but a mounting screw of a wall socket, a steam radiator, or a wire fence may be good enough. Avoid using gas pipes as grounds.

There is no substitute for the antenna, however; it must be long. A couple of hundred feet of wire is a luxury. Fifty feet will sometimes do, if it is clear of tall buildings and trees.

My home lab antenna is a continuous overhead central-heating duct which is 50 feet long. (This one is rather funny, too, since it is grounded at the furnace.) My garage antenna is an unused wire in the telephone line. (Be careful of this one. Some

telephone installations still use this third yellow wire for the ring signal. first, make sure that there is no DC from the yellow to the red and green, then get someone to ring you and make sure that no high-voltage AC appears between the yellow and the other wires. Finally, always couple to such a thing through a 0.01uF 500-volt capacitor.)

If you can string up a wire antenna, try to keep it from lying on surfaces and bumping into aluminum window frames. You can run a wire antenna inside an attic; hang it from short pieces of string under the rafters (the string acting as insulators). You can use any kind of insulating scheme to keep the antenna from resting against large surfaces. Holding it with plastic strapping of some sort, you can stretch the wire taut between elevated fixtures on a roof so that it doesn't rest on the shingles. On the other hand, unlike transmitting antennas, touching non-metallic objects here and there along the way will not be fatal to an antenna's performance.

That it be long is the important antenna consideration, but beyond this, not having it double back on itself is to be preferred. If you can make it long, but it must go out and comeback, keep the two runs as far apart as possible, and if it can be arranged, avoid running the wire in exact parallel directions.

Luckily, I live where there hasn't been a lightning storm in years. If your situation is otherwise, cultivate the habit of grounding your outdoor antenna when not in use, and if you hear a rumble of thunder, ground it quickly with a clip lead and run like a turkey.

DIODES

Dick Kleijer crystal-radio.eu

<http://www.crystal-radio.eu/endiodes.htm>

Which diode can I use best in my crystal receiver?

Maybe you think a diode with a voltage drop as low as possible, then also small signals at the detector circuit are detected. But diodes with a low voltage drop, also have a high reverse current (leaking current), this will load the detector circuit heavier, the Q of the detector circuit reduces, and with that also the voltage across the LC circuit. At a lower input voltage the diode will give much more losses, and it can happen that despite the lower voltage drop of the diode, you have less voltage at the load resistor. Besides that, reduction of circuit Q will also give a less selective receiver.

For every 20 mV less voltage drop, the reverse current will approximately double.

Germanium, silicon, en schottky diodes. Depending on the material they are made from, we can distinguish germanium diodes, silicon diodes and schottky diodes. There are some more types, which are not discussed here.

Silicon diodes have the highest voltage drop (about 0.5 Volt) and are for this reason not very useable for crystal receivers. Unless we use a small DC bias current, which brings the diode already a little bit in conduction.

Germanium diodes have a low voltage drop (about 0.1 - 0.2 Volt) and are often used in crystal receivers. The properties like voltage drop and reverse current can vary a lot between two germanium diodes of the same type. In practice we can

Notes on the Various Components

The crystal set lends itself to parts which have been "scrounged" from far and wide. Don't ever let a dead radio, a 1960-vintage circuit board, or a dead telephone slip through your fingers. From telephones, you can get passably good medium-impedance earphones. From old radios, you can get coils and variable capacitors, output transformers for matching to low-impedance earphones, and cabinets to build your crystal sets into. From old circuit boards with solid-state stuff on them, you can get germanium diodes, or transistors that can be used as diodes. If the family finds the catsup in an orange-juice bottle some day, they will just have to accept the fact that you've used the nice cylindrical plastic catsup squeeze bottle as a coil form.

The Diode Detector

Radio Shack still sells 1N34A germanium diodes--ten for a dollar as cat. No. 276-1123. Mouser also sells germanium diodes--cat. No 333-1N34 and 333-1N60 (\$.17 and \$.25).

Though not always the case, these diodes are in glass envelopes which break rather easily if you are zealous in bending their leads. Also, their leads are often plated iron, and if you fool around too much in soldering them, the plating will come off, the iron will oxidize, and you will find the process of soldering tiresome, if not impossible. Solder 'em quickly, but deliberately, and treat them gently.

You can use a germanium transistor for its base-emitter diode. Typically, people tie the collector and the base together for one diode connection, and use the emitter for the other connection. If the transistor is burned out, you can often tie the collector

and emitter together for one end of the "diode, and use the base lead as the diode's other end.

Silicon diodes and transistors won't work (unless the radio station is breathing down your throat). This is because silicon junctions have a comparatively high forward voltage--typically 0.6V as opposed to 0.3V for germanium junctions. On the other hand, you can apply an external bias voltage to reduce this unwelcome threshold to zero, and a circuit for that is given later.

Another possibility is use of the "Schotky Barrier rectifier"; these begin conducting at 1/3 volt, and they make a loud crystal set. Their disadvantage is that they have a very high capacitance; this is true because they use a large-area metal barrier in the junction. Near 0 volts, their typical capacitance is over 100pF, so use of them means that you have trouble tuning the top of the band. Nevertheless, they are fun to try, and a typical number is the 1N5819.

[You have all heard of the razor-blade detector. You rest a pencil lead (one intended for a mechanical pencil) on the edge of the blade; the oxide inevitably present on the thin edge conducts best in one direction. Like the galena and cat's whisker business, this is not a very good diode, and it's a lot of fuss. Interestingly, it was invented by a prisoner; he probably couldn't get down to Radio Shack.]

Commercially Made Coils

Rather than winding your own coils, you can buy them. The store-bought ones, because there is less market than there used to be, can be quite expensive. Once common place, a ferrite-

Because of the 20 cm distance, there is a loose coupling between the coils.

Connect the probe to the LC circuit.

The earth connection of the probe must be connected to the housing of the tuner capacitor.

The probe is connected to the oscilloscope.

The probe provides a small loading of the circuit, so the Q will not reduce so much.

There are also 1:1 and 1:10 probe's, but these will load the LC circuit too much.

The 1:100 probe I use has a input resistance of 100 M.Ohm, and a input capacity of 4 pF.

The output voltage of the generator must be set so high, that the oscilloscope gives a clear picture of the RF signal.

Because the 100 times attenuation in the probe, the signal generator output must be set fairly high.

When measuring low Q circuits, I must set the generator output to it's maximum of 20 Volt peak-peak.

For measuring the Q: perform the 5 steps described on the top of this page.

The frequency adjustment is done by hand, by turning the frequency knob of the generator.

point is higher in frequency than f_{res} , this frequency we call: f_h .

Step 5:

Calculate the bandwidth BW: $BW = f_h - f_l$. Calculate the Q:
 $Q = f_{res} / BW$

For performing these 5 steps, we can use the following test setup

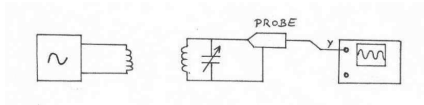

In the schematic above you see from left to right the following components.

A signal generator

A coupling coil

A 1:100 oscilloscope probe

An oscilloscope

Connect the output of the signal generator to the coupling coil having e.g. 50 turns.

Place the coupling coil at about 20 cm from the coil of the LC circuit.

The coupling coil don't have to be high Q.

slug-tuned broadcast coil, the good-ol' Miller 9001, now costs you \$11. (The tapped one, Miller 9011, is nearly \$13 now.)

Nevertheless, trying circuits with those Miller slug-tuned coils is worth doing, because they have such a high Q. Besides having the advantage of a ferrite core, they are wound with "Litz wire." [To conquer the "skin effect" (the tendency for RF current to use only the outside surface of a wire), Litz wire is made of many thin strands of wire, all insulated from one another. The result is low resistance at radio frequencies.] Moreover, those Miller coils are "scramble wound"; their turns do not lie parallel to one another, thereby greatly reducing the distributed capacitance.

Store-bought coils have a funny mounting arrangement. They have a springy metal cap that fits into a 0.3-inch diameter hole. A small tab 1/4 of an inch away from center keeps the coil from turning in its mounting as you adjust the slug. The mounting plate must be thin metal—an aluminum chassis or a fabricated bracket.

Homemade Air-Core Coils

It is easy to make your own air-core coils by winding magnet wire, or even wire-wrap wire, around a cylindrical form.

"Magnet wire" is copper wire which has been coated with enamel insulation; enamel is used because it is so much thinner than other insulating materials. You strip its insulation with medium-grade sandpaper; you test to see if you have gotten down to bare wire with a continuity tester.

There are various types of enamel—some very tough and some fragile. For radio coils, it doesn't matter which kind you use.

(These differences are important to electromagnetics people--designers of motors and transformers.)

Radio Shack has an assortment of "magnet wire"; they give you 40 feet of 22-gauge, 75 feet of 26-gauge, and 200 feet of 30-gauge--Radio Shack No. 2781345. Any electronics supplier or electric motor shop can provide you with magnet wire. Belden Wire Company and Vector Electronics Company sell magnet wire by weight--1/2- and 1-pound spools.

For example, Belden Wire Co. sells "solderable magnet wire" whose enamel is destroyed in the soldering process (as long as the soldering is done at 800 degrees or more). This enamel chafes easily, but it is good enough for these coils; it can be gotten from Newark Electronics. A half pound spool of 22-gauge has the Belden No. 8051, Newark cat. No. 36F1314 (about \$20, ouch). A half-pound spool of 24-gauge is Belden No. 8052, Newark cat. No. 36F1315. (about \$20).

Though it frightens me to tell you this, Mouser has magnet wire, but only in large quantities. For example, they list an 8-pound 22-gauge spool of magnet wire--cat. No. 501MW22H (4000 feet). I bought one; it only cost me \$80, and it is very nice wire made by Phelps Dodge. You can use it as antenna wire as well, but that's a lifetime supply for you and your neighbors.

Typical coil forms for the broadcast band are cores from paper rolls--toilet-tissue cores or kitchen-towel cores, cardboard mailing tubes, or plastic tubes (perhaps bottles with the tops and bottoms cut off). Plastic ones are the best; paper and cardboard take on moisture that causes losses and lowers the Q.

MEASURING THE Q OF LC CIRCUITS

Dick Kleijer crystal-radio.eu

<http://www.crystal-radio.eu/enqmeting.htm>

In theory we can determine the Q of a circuit as follows:

Step 1

Couple a RF signal generator to the LC circuit. The coupling between generator and LC circuit must be loose, otherwise the output resistance of the generator will load the circuit and reduces the Q.

Step 2:

Set the generator to the frequency at which you want to measure the Q. Adjust the LC circuit (turn the tuner capacitor) so you have maximum voltage over the circuit, the circuit is now in resonance, this frequency is the resonance frequency of the circuit (f_{res}).

Step 3:

Measure the voltage over the LC circuit at resonance frequency (f_{res}).

Step 4:

Vary the generator frequency a little above and below f_{res} . and determine the two frequencies where the voltage over the circuit is 0.707 times the value at f_{res} . The voltage reduction to 0.707 times, is the -3 dB point. One -3 dB point, is lower in frequency then f_{res} , this frequency we call: f_l . The other -3 dB

Figure 6.

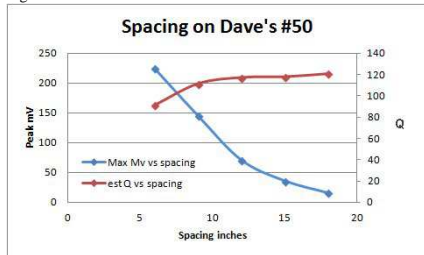

Securing a coil against a panel, especially a wood panel, will cause losses and will add distributed capacitance. Therefore, mount your coils on spacers.

My current favorite plastic forms are the "pill bottles" (vials, 30-dram and 60-dram sizes). These are available from sympathetic pharmacists (you have to convince one that these are for your crystal set).

The 60-dram vial measures 2 inches in diameter--more or less--and 5-1/4 inches long. The 30-dram vial is also 2 inches in diameter, but about 3 inches long (they leave a little room for cotton at the opening). The minor disadvantage of these bottles is the slight taper--smaller at the bottom. Because of the taper, all coils should be wound from the bottom up, so that succeeding turns drift toward the coil, not away from it.

A pill bottle is rather nice for mounting; you just screw the cap to the board and snap the bottle into place so that it stands vertically. This way, spacing the coil away from the board is automatically taken care of.

The ends of windings are anchored by weaving them in and out of a couple of holes. Consider the process of installing a 17-turn antenna winding at one end of a coil form. About 1/2 inch from the end of the form, you poke two holes which are perhaps 1/2 inch apart. You thread the magnet wire through one of the holes--from outside--and pull it through about 8 inches. Then, you poke the wire through the neighboring hole from the inside and pull it taut (giving you 7-1/2 inches of free end now. You now repeat the process; poke the wire down through the first hole and pull it taut, then poke it back out the second hole and pull it taut. This will fix the end firmly in place.

Crumple up the free end and stuff it into the form where it will be out of your way. Next, get a piece of tape ready and stick it to the edge of your workbench where you can grab it handily. Turning the form slowly, wind your 17 turns, every once in a while pressing them together with three or four fingernails so that there are no amateurish spaces between turns. When you are finished (or when you get tired and need to take a break), grab your piece of tape off the edge of the bench and slap it across the coil to hold it in place.

Once the winding has been completed and the tape is holding it, cut the wire to an 8-inch length. Poke two more holes just beyond the winding and weave the free end in and out as before.

Normally, margins of 5/8 inch are left at the ends of the form to permit screw holes to be drilled for mounting. Sometimes, as with the double-tuned circuit using pill bottles, you need to place a winding at the very end of the form; in this case, passing the first half-turn through another pair of holes opposite the ones fixing the end of the wire will keep wraps from spilling off the end of the form.

As an example of anchoring the end-most turn, consider the problem of winding 20 turns of wire around a plastic soda-bottle cap (making a coupling coil for some of these circuits). Very near the closed end of the cap, two pairs of holes are drilled, diametrically opposed. The wire goes in and out of the first pair and is pulled through to a length of 10 inches; then, the end is woven in and out of the opposite pair of holes to firmly "fix the end." A ridge at the open end of the cap means that the last turn can be anchored in one pair of holes; there is no danger of turns falling over the ridge.

In figure 5 above I have attempted to cast Dave's measurements into something similar to what I am doing, which is looking at the -3db BW and Q at 1100khz. I finally produced the above spreadsheet where I simply smoothed the data for the 1000khz case and estimated the bandwidth at -3dB. This makes a LOT of assumptions of course. Mostly I assume that the +/-10khz measurements are well above the resonance skirt so my smooth curve is not unreasonable.

The #50 set then appears to have, at 1000khz, a -3db bandwidth of around 8-11khz depending on diode and/or spacing between the tank and antenna unit giving loaded Q's of 91-125. These numbers fall in the range of what my own data lead me to expect. Ken Kuhn's page on Resonant Circuit suggests the "typical" QL at 1Mhz ranges between 20 and 100 and Dave's #50 set is certainly beating the best of that.

In the final figure 6 I have taken my estimated results above and looked at how Q and peak voltage (assuming constant conditions other than the spacing between the antenna and detector units so this ought to reflect power as well). It is quite apparent that the set is rapidly losing output power while Q improvements are flattening out as the spacing between tank and antenna tuner grows to 18 inches. It would appear that a -3db loaded Q of 125 is near the limit of what can be expected in a crystal set.

skill, experience and usage of the best (\$\$\$) materials available. I take this to be just about the most of what can wrung out of the sky with a crystal radio. Dave's protocol is rather different from my own and he did not make a specific -3dB bandwidth measurement so what I do from here on takes many liberties with his work, my sincere apologies in advance!

Figure 5.

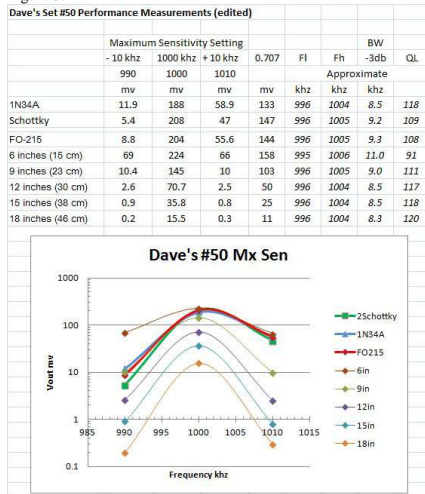

You will see that most of the coils in these circuits require a tap one-quarter or one-third of the way up from ground. A tap can be arranged in two ways. The most elegant way is to sand a little bare spot in the wire when you get to that point in the winding, and solder a pigtail of insulated stranded wire to this bare spot. The other way, while it is a little more crude, is to bend the enameled wire double for an inch or so, then twist it several times so that a loop will emerge from the windings at this point in the coil.

Of course, you can have as many taps as you want. This is one way to match the detector most properly to the earphones--getting sufficient voltage to drive the earphones, while preserving the Q by minimizing the load from the earphones.

When it comes to connecting the coil into the circuit, cut the ends to slightly longer than the desired length and sand about 3/4 of an inch bare and make the connections. If the tap is a twisted loop, don't cut it, but just sand the end of the loop bare and make that connection. Test all stripped segments with a continuity tester; you cannot feel whether you have gotten down to copper, or just roughened the enamel.

Traditional dimensions for radio coils is to design them in such a way that the diameter and length are nearly the same. (Having the length equal the diameter makes the so-called "square coil" which is popularly used.)

There is an approximate formula given in the Reference Data for Engineers, copyright 1964 by IT&T, by which you can calculate the inductance of single-layer coils within a few percent. This expression is:

L (inductance in microHenries) equals n squared times r squared, divided by the quantity $9 r$ plus $10 l$.

Lower-case "l" is the length of the coil in inches, "r" is the radius in inches, and "n" is the number of turns.

For the broadcast band, we want the inductance to fall somewhere around 220 microHenries. To save you the algebra, a 2-inch-diameter form will require secondaries of 80 turns of 22-gauge wire, 77 turns of 24-gauge wire, or 70 turns of 26-gauge wire.

[Because the 60-dram and 30-dram vials are tapered, it is good to make the windings 5% too long to compensate for this.]

Notes on Wire Gauging

The copper wire gauging system used in the U.S. is "the American Wire Gauge" (AWG). The wire diameter changes by a factor of 2 every 6 gauges. Thus, since 26-gauge wire is 0.016 inches in diameter, 20-gauge wire is 0.032 inches in diameter, and 32-gauge wire is 0.008 inches. (These are approximate dimensions, and the enamel adds perhaps 0.001 inches.) Since cross-sectional area depends on the square of the radius, this area changes by a factor of 2 every 3 gauge sizes.

Now, if you can remember three wire sizes, you no longer need a wire table. Good-ol' 22-gauge wire (0.0253 inches in diameter) reminds me of my micrometer--25 thousandths per turn, or 40 turns per inch. Wire of 24-gauge (0.0201 inches) gives you 50 turns per inch. Wire of 20-gauge is about 32 thousandths.

Figure 4.

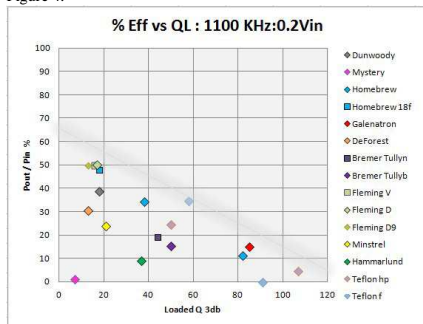

Here is the bottom line, Q versus Sensitivity, efficiency in this case. On this plot it is readily evident that I have built my fair share of loser radios, but also a good number of sets which push boundary of what can be achieved in terms of compromise between Q and sensitivity. Looking at the plot it is fairly easy to imagine a sloping line or zone running from 0 Q at 60% efficiency down to 120-130 Q at 0% efficiency. Beyond this one will probably never go with tank and antenna tuner alone. It will be time to start adding traps to your bag of tricks. Recall that the above is for the 1100khs frequency and that Q is a function of frequency.

In order to explore this final conclusion, I have taken a look at Dave Schmarder's excellent bandwidth analysis of his #50 contest set. This set is a superb work of craftsmanship and

optimal load resistances for this case was similar to or lower than that for the 0.2Vpp input case.

With all that said, the plot in figure 2 is messy but the impression is that of increasing Q with increasing RL. I view the plot as having a number of small groupings of measurements with similar conditions, each showing higher Q's associated with higher load resistance.

Figure 3.



Figure 3 is most obvious with the clear benefit of good set efficiency on output power. An efficient set will better approach the maximum power transfer desired. High Q plays a part here. Still, there is always the tradeoff between selectivity (high Q) and sensitivity. An efficient set delivers more power to the load, but to go after Q you will ultimately be sacrificing sensitivity.

Tuning Capacitors

These are the most hard-to-come-by items in our modern age. Big radios don't have mechanical tuning any more, and little radios will soon give it up. The best tuning capacitors are being harbored in antique radios. Built into metal frames, they have a stationary set of plates ("stator") and a movable set ("rotor"). Many of these are multi-section--usually dual.

Unfortunately, most of the dual ones do not give us two usable sections, because the sections are different sizes and values. The smaller one, used to tune the local oscillator in superheterodyne sets, can be ignored and only the large one used. However, some low-budget radio makers of the 1950s used dual variable capacitors whose sections are identical; for double-tuned crystal sets, these are worth "breaking and entering" for.

Because many salvaged capacitors are fitted with dial-cord pulleys instead of knobs, you may end up making a knob for the odd-sized shaft after the pulley has been pried off.

The rotor is usually common to all sections. Since it is usually part of the frame, and since you must operate it with your hand, it is grounded. Connection to the rotor is almost always done via a mounting screw; solder lugs on the frame are rare. Each stator almost always has two solder lugs, one on each side of the stator, and these are electrically identical.

Radio Shack doesn't even have a suitable capacitor. The only one they show of sufficient range is a "compression-type trimmer" that you have to tune with a screwdriver.

The most readily available modern tuning capacitor is a Mouser unit suited for pocket radios. It has two main sections

that go from 5 to 266 picofarads, and four 7pF screwdriver-adjustable trimmers which we can ignore for these sets. The Mouser cat. No. is 24TR218 (\$2.71). The only trouble is that they don't supply a knob for the accursed thing; you have to make your own and secure it with a 2.6mm metric screw.

This Mouser unit is festooned with solder lugs. Two sets of three long ones are for the trimmers, which we don't need. There are three short lugs, two on one edge and one on the far corner of an adjacent edge. The lug which is off by itself goes to the rotors of both the large sections; the two coming out the same edge are the stators of these sections.

You can mount the Mouser capacitor by sticking its one free edge--or its back--to the chassis or breadboard with double-sided foam tape.

The required range is perhaps 30pF to 365pF. Actually, most go slightly higher than this--400pF or so, and their lower limit can be nice and low--5pF for each section of the Mouser ones. The Mouser units require that you connect the two main sections together, giving you 10pF to 532pF. The important thing is to have enough range to cover the whole broadcast band (given that the coil will have a lot of distributed capacitance).

(For double-tuned sets with matching coils, the Mouser units can be hooked up another way. Two of their 2-gang units are used; the rotors are connected together, the stators of Section A of the two units are connected together, and the stators of Section B are connected together. In this way, you have ganged capacitors; they both have to be at maximum to tune the bottom of the band, and they both have to be minimum to get to the top of the band.)

a generic transformer that would work well with many or all minus the complicated switching.

In my testing protocol therefore, I included the important step of determining the optimum load resistance for the set under test conditions. I certainly part company with the school of thought that says to test all sets

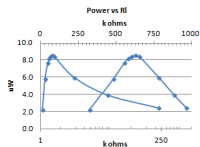

exactly the same way, including same diode (1N34A typically) and same test load. Sets are designed to work best when impedance matched and at the back end that generally means a load matched to the tank/diode combination that delivers the maximum power. At right above I show a small plot where I varied the load resistance over a wide range and calculated the output power of the set. (I give the plot with both a linear and a more appropriate log scale). This should demonstrate the importance of optimizing the load resistance.

Optimum load resistance depends on both the tank Q and that portion of the diode detecting the signal. That in turn depends on the signal level. Very weak signals will be rectified in the square-law region of the diode characteristic and require relatively high (and variable) load resistances. Normal to strong signals will be rectified primarily along the peak-detection portion of the diode characteristic and require lower load resistance with less variation. Not shown in the above spreadsheet, I also ran measurements with a 2.0Vpp input. With this stronger signal, rectification was taking place farther out on the diode characteristic. As expected, the measured

If you are serious about getting DX and doing a lot of heavy lifting, you will need a good antenna tuner as part of your set design.

Figure 2.

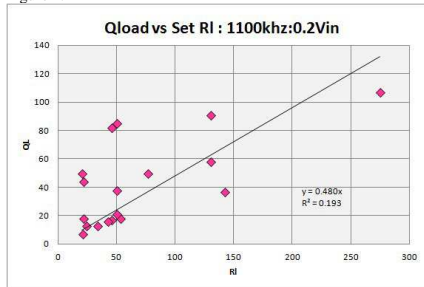

At the back end of the set things get a bit messier and are not east to show with a simple two-component plot. Here I have chosen to highlight the importance of the proper load resistance on the set loaded Q. In my set testing I have tried to pay close attention to the importance of the load on the tank and diode. Early on I considered construction of an output transformer unit that would work with different radio's as well as with different phones. Such a design can be found on Ben Tongue's excellent and highly technical web site. The plans were well beyond what I was able/willing to take on so I turned my attention to discovering just what load resistance exactly do my sets require for maximum power transfer. After all, if I found only a small range typical values, I might design

Caution: When you transport or store open-frame variable capacitors, be sure that the plates are fully meshed. If a capacitor is partly open, the plates of the rotor can be easily bent out of shape.

LC Resonance

As any radio ham knows, the expression for resonance, whether it's a series- or parallel-tuned circuit, is:

f equals 1 over 2 pi times the square root of L times C.

L is the inductance in Henries, C is the capacitance in Farads, and lower-case f is the frequency in Hertz.

Consider the example of 220 microHenries and 400 picoFarads. Expressed in scientific notation, the capacitor is 4 times 10 to the minus 10th power, and the coil is 2.2 times 10 to the minus 4th. Their product is 8.8 times 10 to the minus 14th. The square root of this is 2.97 times 10 to the minus 7th (you have to divide the exponent by 2 when you take the square root). Multiplying this by 2 times pi (2 times 22/7ths), we get 18.7 times 10 to the minus 7th, or 1.87 times 10 to the minus 6th. The reciprocal of this is 0.535 times 10 to the 6th Hz (the exponent changes sign when you bring it up into the numerator). Ten to the 6th Hz is a megacycle, so the result is 0.535 megaHertz.

Earphones

These are becoming a troublesome item to get, but I've solved it. Crystal sets require high-impedance earphones. By high-impedance, I mean 2,000 ohms or more. Most of the traditional hobby types were electromagnetic; a permanent magnet put a

bias on a diaphragm by pulling it in a bit, and then coils around the poles of the magnet would cause the field to fluctuate, causing the diaphragm to move back and forth.

Sometimes seen in junk collections, brands to look for are Trim, Brandes, Telephonics, Cannonball, Scientifics, Baldwin, and Utah. Short of these, you can use the earpieces from broken-down telephone handsets--fashioning a headband as best you can. Trim "Dependables" used to be issued by the Library of Congress for talking book listening. If you know someone who has those, get them somehow, even if you have to rough 'm up a bit.

Military surplus phones, such as those made by Utah, were all medium-impedance--600 ohms. These and telephone earpieces must be coupled to the crystal set via an autotransformer (described herein).

Another type, which affords high impedance, is the so-called "crystal earphone." Older ones used a crystal of "Rochelle Salt" as a Piezo-electric element to drive a foil diaphragm. Old ones of these are most likely bad now; the Rochelle Salt takes on moisture and loses its properties over time. New ones have ceramic elements.

They don't look resistive; they electrically appear as capacitors. For this reason, the diode detector may have to be provided with a load resistor in order to perform well. Finally, if you have some around and you are playing with active circuits, you should know that crystal earphones are destroyed by DC, so other than on your crystal sets, put a resistor across these earphones and capacitively couple them.

From the data above some interesting observations can be made.

Figure 1.

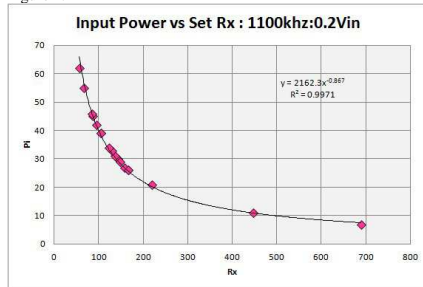

In figure 1 above I show the relation of the input power versus the set resistance. The quality of the fit reflects that fact that this is largely a calculated value, but it does illustrate the importance of having a low input impedance to match that of the antenna. This is not often considered in discussions on impedance matching but is critically important. The antenna has an impedance in the 25 - 50 ohm range, not easy to get this in a set without quality parts and construction. My sets typically have an input impedance in the low 100's ohms and only two of my sets really get down to the 50-60 ohm range giving a good match to the antenna. Both of these are double-tuned sets with a tuggle front end.

Measured Qloaded at 1100 KHz										
Radio	Vin	Pin	Pout	Eff	BW	Ql	Rx	Rl	Rd	
	V	uW	uW	%	KHz	-3Db	ohm	kohm	kohm	
Bremer Tully	0.2	30	4	15.4	22	50	143	20	200	BAT 46
Bremer Tully	0.2	26	4	19.2	25	44	166	21	18	1N277
DeForest 0d	0.2	42	10	30.4	85	13	95	24	18	1N277
Dunwoody	0.2	31	10	38.7	62	18	136	21	200	BAT 46
Fleming D	0.2	33	14	50.1	63	17	129	45	170	D18
Fleming D	0.2	27	12	49.3	83	13	158	33	2	D9E
Fleming V	0.2	34	14	49.8	70	16	122	42		6C19P
Galenatron	0.2	21	2.8	15	13	85	219	50	18	1N277
Hammerlund	0.2	26	2	8.9	30	37	166	142	150	FO 215
Homebrew 11cm	0.2	39	10.7	34.3	29	38	104	50	18	1N277
Homebrew 18cm	0.2	55	4.5	11.2	13	82	86	45	18	1N277
Homebrew 18cm	0.2	29	11.8	47.8	61	18	147	53	150	FO 215
Teflon 8	0.2	45	8.5	24.5	22	50	86	76	575	HP2835x4
Teflon 14	0.2	62	2.0	4.6	10	107	56	275	575	HP2835x4
Teflon 8 215	0.2	46	12.3	34.8	19	58	85	130	150	FO 215
Teflon 14 215	0.2	7	0.0001	0.0015	12	91	689	130	150	FO 215
Minstrel	0.2	39	8	23.8	51	21	104	50	160	1N60 schott
Mystery	0.2	11	0.1	1.2	163	7	446	21	28	1N34A
	Av ->	34	7	26	46	43	173	68	153	

The above table of measurements were made at a nominal frequency of 1100khz and input voltage of 0.2Vpp as indicated on a digital signal generator following the protocol outlined. I give the radio name under test should you wish to refer to my pages for more on each set. The columns as follows:

Vin = 0.2V pp (0.71mV rms)

Pin = input power in uW into the set (after the dummy antenna)

Pout= output power across the load resistor in uW

% Eff = 100 * Pin/Pout

BW = bandwidth in khz at -3db

Ql = calculated loaded Q of the set

Rx = the set input resistance presented to the antenna

Rl = measured optimum load resistance for maximum power transfer

Rd = Diode junction resistance Rd used in the set

Mouser has high-impedance "crystal earphones," Mouser No. 25CR060 (\$1.56). In general, pairs of magnetic earphones are connected in series to get their impedance as high as possible. Pairs of crystal earphones are connected in parallel. Earphones of the wrong impedance can be used if you match the impedances with transformers. For example, small loudspeakers can be used if you drive them with an audio-output transformer; the speakers, connected in series, go to the low-impedance secondary of the transformer (a 4- or 8-ohm secondary), and the primary winding goes to the earphone connections at the crystal set. Medium-impedance earphones, such as telephone receivers, can be matched with an autotransformer; if you have an output transformer with a center-tapped primary winding, the medium-impedance earphones, connected in series, go between the center tap and one side of the winding, while the whole winding goes to the earphone connections on the set (the secondary of the transformer is left open).

Impedances are transformed by the square of the turns ratio. For example, when you drive medium-impedance earphones with half the winding as described above, you see four times the earphone impedance across the whole winding.

Anyhow, I made a pair of earphones using two 8-ohm 2-inch loudspeakers connected in series (an earphone impedance of 16 ohms). Then, I used a miniature output transformer--8 ohms to 1.2K--to drive them. (The series-connected speakers are connected across the 8-ohm secondary winding, while the 1.2K primary goes to the earphone connections on the set. If it has one, the centertap on the primary is unused.) Since the secondary is looking at 16 ohms, the impedance appearing across the primary is 2.4K. I glued the speakers to stiff cardboard disks, then covered the backs with disposable

drinking cups. The headband was fashioned out of coathanger. They could further be improved by putting foam shrouds to seal around the ears, thus improving acoustical coupling.

I tried my best to make "Walkman" earphones work, but to no avail. Since they are open earphones, and have small diaphragms, they are somewhat inefficient.

Mouser has a fine output transformer for matching to low-impedance headphones (like my PM speakers and drinking cups); it has a center-tapped primary of 20K, and a center-tapped secondary of 4 ohms--Cat. No. 42KM019 (\$1.63). A less drastic impedance-matching transformer is the 8-ohms to center-tapped 1.2K--Mouser No. 42KM003.

Vacuum-tube radios have salvageable transformers of two types, center-tapped primaries for 2-tube "push-pull" amplifiers and high-impedance nontapped primaries for "single-ended" circuits. I kind of remember that 10K to 3.2 ohms was common.

Try everything--half the primary, the full primary, and try various output taps if the transformer has them.

Crystal sets don't give you much surplus power, so acoustic coupling to the ears is a critical factor.

Matching the Detector and the Earphones

Since the impedances of earphones you are likely to find are "by guess and by gosh," and the Q they are effecting is largely unknown, matching by experimentation is the best approach. The following effects can be noted to aid in troubleshooting:

- 11) Adjust the frequency above and below f_{res} until the output level falls to the level calculated in step 10 above. These frequencies are f_{high} and f_{low} . Record these.
- 12) The -3dB bandwidth = $f_{high} - f_{low}$. Loaded Q (QL) = f_{res} / BW
- 13) Take the generator output peak-peak voltage recorded in step 2 above and convert it to rms voltage as follows: $mV_{rms} = mV_{pp} / 2.829$. This is Lauter's RF voltage E1 mV.
- 14) Measure the RF voltage across the 10 ohm resistor on the dummy antenna. This is Lauter's RF voltage E2 mV.
- 15) Input current to the dummy antenna = $I_{in} = E2/10$ (mA)
- 16) Input power to the dummy antenna = $P_{in} = E1 * I_{in}$ (uW)
- 17) Power loss in the dummy antenna = $P_{da} = I_{in}^2 * 25$ (the dummy antenna resistance)
- 18) Power delivered to set = $P_x = P_{in} - P_{da}$ uW
- 19) Set input resistance = R_x ohms = E_x / I_{in} where $E_x = E1 - (I_{in} * 25)$
- 20) Set output power (uW) = $P_{out} = V_{out}^2 / R_l$ in ohms
- 21) Set % efficiency (sensitivity) = $100 * P_{out} / P_{in}$

Having built a fair number of sets, and with varying quality, all the above protocol was developed to test my sets. What follows now is a discussion of how my sets stack up against each other and some notes on what one may expect in a crystal radio performance-wise. I give a summary table below of the essential data gathered on each of my sets.

Table 1

Once I find the optimum load resistance, I set the pot to that and proceed to the main testing for sensitivity and bandwidth/Q measurements.

Test Protocol as follows:

- 1) Connect the set to be tested between the dummy antenna and measurement load as per the above diagram.
- 2) Connect the signal generator to the dummy antenna and set the frequency and voltage output. I typically test in the center of the BCB at 1100kHz and use a 200mVpp output sine wave.
- 3) Set the load resistance to somewhere around 50k ohms. The exact value is not critical as it will be adjusted later.
- 4) Connect the DVM and tune the set to peak the output voltage. Care here is amply rewarded, especially with double-tuned sets.
- 5) Once peaked it is necessary to adjust the generator frequency to re-peak the output voltage as hand-capacitance or other factors may have prevented perfect tuning. You now have your set properly tuned for maximum output. Presumably this also means the best possible impedance match between the set and dummy antenna. This is the resonant frequency (f_{res}).
- 6) Record the frequency and output voltage.
- 7) Now find the optimum load resistance. This is done by making a series of paired measurements of load resistance and output voltage. Power in $\mu W = mV_{out} * R_l$ khoms.
- 8) Set the load resistor pot to the value where power output is highest, this is the optimum load for the test. Record this.
- 9) With the signal generator re-peak the output voltage and re-record the resonant frequency (f_{res}) and output voltage (V_{out} mV).
- 10) Multiply mV_{out} by 0.707 to find the -3dB level.

If the set distorts on weak stations, either the diode is not seeing enough voltage (the tap is too low), or the impedance of the earphones is too high and the detector is not sufficiently loaded. If the set is nonselective ("broad as a barn"), the impedance of the earphones is loading the coil and greatly reducing its Q, or the tap is too high on the coil.

3DB tapping:

The serious experimenter will want to build his secondary winding with a selection of taps for the detector. Since the impedance--and the power--go up as the square of the turns ratio, adopt the systematic scheme of doubling the impedance every tap (going in steps of 3dB). This would require taps at the following percentages of the winding (starting at the grounded end): 18%, 25%, 35%, 50%, 70%, and the full winding. Notice that these percentages are related to each other by the square root of 2; the voltage and current either go up by 1.414 or down by 0.707 as you select neighboring taps, while the impedance and power are either doubled or halved as you select neighboring taps.

Solder these taps to successive positions on a 6-position rotary switch. The arm of the switch will then go through the diode, then through the earphones to ground, with the earphones being shunted by 0.005 μF (see the circuits to follow).

Crystal Radio Circuits

I give my impression of the performance of any set I have in my collection. I tested them on my little furnace duct antenna, doing so in the daytime.

Some of these have variable coupling between the antenna and the main tuning coil. This creates a sort of combination volume

control and selectivity adjustment. In general, the looser the coupling, the more selective the set becomes, although this is at the cost of sound volume. If a station is blustery enough to over-ride all interference, tighten the coupling, turn it up and dance to it.

I won a science prize once for making the world's smallest receiver. The circuit follows:

Circuit for the World's Smallest Receiver

The antenna goes through the diode to ground. The earphones are in parallel with the diode.

It gets everything all at once. This can be rather fun. You can hear zealous spiritual leaders in shouting matches with "rap musicians." When a famous politician's speech is carried by all the networks, you can hear three or four of him, all accompanied by drum machines.

[It is worth noting that at one time, this was good enough; in the very early days of radio, all the stations were trying to transmit at a wavelength of 300 meters--all more or less at 1 mHz.]

Perhaps the most common of circuits uses the distributed capacitance of the coil to make a half-baked LC circuit. A long coil is required, perhaps 200 turns of No. 26 wire on a cardboard or plastic form (such as a mailing tube, the core from a roll of kitchen towels, or the 60-dram vial). Then, for mechanical stability, "dope" (coat) the coil with model cement. By sanding to and fro with medium sandpaper, create a strip of exposed copper across the windings so that a metal "tuning slide" can make contact with the coil. Next, fashion some sort

radios to be tested a 1N34A diode and then use a standard 2k ohm load resistance to make the output measurements. This may give a standard and comparable result, but it does not insure a good impedance match and does not reflect the intended usage and setup of many crystal sets, especially sets intended for high-performance. Here I am interested to learn just what is the optimal load resistance for my set under the test conditions. Note the caveat "under the test conditions". This may not reflect actual usage unless you take precautions. You will want to set the generator to an input voltage similar to what you expect the radio to receive in actual operation. You will probably want to signal level work the diode in its peak-detection region but not so high as to saturate the diode, (In making a loaded Q measurement you want to make sure that the diode impedance stays constant; otherwise, the change in diode impedance (as the tank attenuates the signal before the diode) will change the load on the tank and the bandwidth measurement won't really reflect the Q of the tank). Finally, for the output voltage you need a good voltmeter with very high input impedance that will not load down the set under test. This really means a good DVM. I use a used Keithley 192 bench meter with a 2M ohm input impedance, and as a backup a used Keithley 180 bench electrometer. Overkill perhaps, but for just in case...

Getting back to the load resistance then, my protocol is to find the optimum resistance to deliver the maximum power (not voltage!) to the load. This is a bit of a tedious process but will amply rewarded. Having tuned and peaked the set to the measurement frequency, I then take a series of resistance/voltage readings to find the maximum power output. In my circuit this is accomplished with the variable 1M pot. The resistance meter and voltmeter cannot be connected to the load at the same time making this a tiresome road to follow.

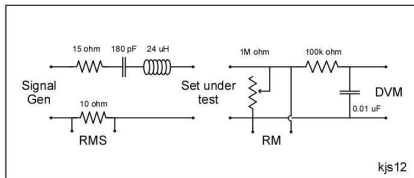

For the tests I originally found an old analog signal generator on ebay which I sadly found to be wholly inadequate. The unit was by no means cheap but the dial was difficult to read with any precision and the "play" in the dial made readings hopelessly inaccurate. Finally, it gave no indication of the attenuation or voltage output levels, rms or pp, of the signal. I have since found a nice, reasonably-priced new digital unit, (max's out at 2Mhz so strictly for AM band work) that gives good readings, gives me the output voltage level in pp, and can even produce different wave forms. I recommend if you are seeking to equip your lab, go this way from the start!

To calculate the signal input power you will need a good rms voltmeter. This is a non-trivial item and, after my experience with the vintage signal generator I was leery of getting a used meter. In any case, an expensive dedicated single-use piece of equipment seemed extravagant. For this measurement I have found entirely acceptable results using an oscilloscope which, of course, is useful for so much more and belongs in your lab regardless!

It is on the back end of the measurement where I diverge from Lauter's protocol significantly. He recommends placing in all

of slider (perhaps a ground-off hacksaw blade anchored at one end) which can be used to make contact with the bared coil windings anywhere along the length of the coil.

What you have created is a coil with adjustable length. Only one end of the coil is connected to anything; the other coil connection is the slider. A circuit for the simplest tuned set is as follows:

Simplest Tunable Crystal Radio

The coil slider is grounded. One end of the coil goes to the antenna; also connected to this end of the coil is one end of the diode. The other end of the diode goes through the earphones to ground. The earphones are shunted by a 0.005uF capacitor.

The disadvantage of this circuit is that it is broad as a barn--for two reasons. First, the tuned circuit is low Q because of the resistance of all that wire used in the coil; tuning the set with a variable capacitor means that a shorter coil could be used. Second, no attempt is made to efficiently match the earphone circuit to the "tuned circuit"; unless very high-impedance earphones are used, the load that they present lowers the Q even more.

Standard LC-Tuned Crystal Radio Circuit

This was copied from a Knight Kit (Allied Radio) set purchased in the 1950s. The variable capacitor goes from 22pF to 400pF. It uses a Bakelite coil form measuring 1-1/2 inches in diameter and 5 inches long. The coil, wound with 22-gauge magnet wire, has a primary (antenna coupling) winding of 17 turns placed at the cold end of a secondary (main tuning)

winding of 120 turns. The detector is taken from a tap which is one-fourth the way up from the cold end-- of the secondary 30 turns from the grounded end. The separation between the two windings is 1/4 inch.

The antenna coil, 17 turns of wire at one end of the form, has its outside end going to the antenna, while the end nearest the secondary is grounded. This end of the secondary is also grounded. The other end of the secondary goes to the stator of the variable capacitor; the rotor of the capacitor is grounded. A tap on the secondary which is 30 turns from the ground end goes through the diode, then through a 0.005uF disc ceramic capacitor to ground. The earphones are connected across this ceramic capacitor.

This can be built on a 2-inch coil form; just change the proportions. For example, 80 turns of 24-gauge wire--or 85 turns of 22-gauge wire-- on a 2-inch-diameter form will do; I like the detector tap to be at 25 turns. The antenna primary can stay at 15 or 17 turns; an embellishment is to wind a 25-turn antenna winding with a tap 9 turns away from the antenna end, using two antenna binding posts for selectable coupling.

This set is very selective, but not very loud. I am able to get ten stations, seven of which can be isolated enough to listen to. It can be jazzed up a bit by providing it with variable antenna coupling:

Variable Coupling on the Standard Set

Wind 20-turns of 26-gauge wire on the plastic cap of a plastic soda bottle. Affix this cap to a nonmetallic stick of some sort, and fashion a sliding arrangement that permits the cap to be moved in and out of the grounded end of the secondary

RADIO TEST

Kevin Smith

<http://www.lessmiths.com/~kjsmith/crystal/rtest.shtml>

OK, now that you have built a radio, or several, how do they perform? Without a bit of objective testing you will never really know. I have often read descriptions of radio performance such as "tunes very sharply" or "separates two closely spaced stations" and/or etc. These are qualitative descriptions that do not really give you much information. To know your radio, it takes some measuring. I am making the assumption here that, as a homebrew radio builder, you will find tinkering and measuring your sets just as interesting as their design and construction.

For testing, I have pretty much lifted the excellent procedure outlined by Charles Lauter with a few modifications to suit my own philosophy. I will give my own protocol but first let's look at the needed equipment and test setup. Testing a crystal set requires two pieces of homemade equipment, a dummy antenna in front of the set which allows measurement points, and a measurement load at the back end. Other pieces of equipment include a signal generator, an rms voltmeter, a resistance meter, and a good digital voltmeter. Circuit schematics for the homebrew components are shown below.

automatically. These measurements will definitely determine which are the best Xtal sets, circuits, or components.

Happy Testing

winding--from an inch separation to where the coupling coil is encircled by the cold end of the secondary.

Scrap the 17-turn antenna winding on the main coil form. One end of the bottle-cap coil is grounded, while the other end goes to the antenna.

Popular Mechanics Variation

A variation on this basic circuit appeared in the January 1977 issue of Popular Mechanics. The coil was wound on a "salt box" (3-1/4 inches in diameter). The junction between the antenna coil and the tuned secondary is a tap on an overall winding--14 turns below the tap for the antenna coil and 32 turns above the tap for the secondary.

This "tap" is grounded. The antenna goes to the end of the 14-turn segment. The rotor of the capacitor is grounded. The stator goes to the end of the 32-turn segment. The end of the 32-turn coil also goes through the diode, then through the earphones to ground, with the earphones being shunted by 0.005uF.

The editor has not built this Popular Mechanics set, but the closeness of its primary and secondary windings--delineated only by a tap on the continuous coil--will probably make for a loud set with poor selectivity.

* * *

A Double-Tuned Crystal Radio Circuit with Variable Coupling

Two 2-inch-diameter 30-dram pill bottles (vials) are used. The bottoms and caps are drilled to accommodate a wooden dowel

or plastic rod. One of the vials is fixed by winding tape around the rod inside the bottle and under its cap; the other is permitted to slide a distance of perhaps 2 inches. When moved toward one another, the vials must be able to touch bottoms.

Matching coils are wound on the vials--85 turns of 22-gauge or 80 turns of 24-gauge wire. These are started as close to the bottoms as you can get, so that they can be brought quite close together. The secondary is tapped 25 turns up from the bottom, or even better, taps are placed at 15 turns, 20 turns, 28 turns, 40 turns, and 56 turns. (If multiple taps are created, connect them to successive positions of a 6-position rotary switch, with position six going to the hot end of the full winding.)

The rotors of two 400pF variable capacitors are grounded. The antenna goes to the far end of the untapped coil; the bottom of this coil goes to the stator of one of the capacitors. The bottom end of the tapped coil is grounded, with its top end going to the stator of the other capacitor. The tap (or the arm of the rotary switch) goes through the diode, then through the earphones to ground. The earphones are shunted by 0.005uF.

Because the coils are matched (except for the load the detector puts on the secondary), you can get away with a ganged 2-section variable, although having separate variable capacitors gives you some freedom to "detune" the set as an aid to interference elimination. Remember, the two sections of a ganged tuning capacitor must be identical.

With this set, I was able to receive ten stations, eight of which could be isolated well enough to listen to.

2. Increase the Signal Generator output until the DVM reads 1.414 volts DC. This will now be the new value for the input voltage "E1". Maintain this value for the rest of these tests.

3. Decrease the effective Xtal set coupling until the DVM reads 1.000 volts DC. This may effect the Xtal set tuning. If so retune the Xtal set to the Signal generator frequency and repeat steps two and three. Remember to keep E1 constant.

4. Again measure the bandwidth using the previous method above. Now go back and measure the sensitivity again.

5. This process can be repeated over and over for better and better selectivity.

This bandwidth will be less (narrower) than when the Xtal set was adjusted for maximum output.

Xtal Sets with more tuned circuits and variable coupling will have in better selectivity.

Now lets see what this reduced coupling did for the Type SCR-54-A. The bandwidth at -3db is now only 9 kHz and the -20 db bandwidth is now 73.6 kHz. Lets see what this change did to sensitivity. Crystal Set efficiency decreased from 21.5% to 12 35% and total efficiency decreased from 6.83% to 3.67%. These efficiency numbers were expected because they are about a -3db decrease which is the same as the decrease in step 3 above.

The set of three measurements above is then repeated at each of the test frequencies listed above.

All of the above measuring may sound like a lot of work but once the equipment is in place the tests do not take long to perform. I use a computer spreadsheet so that after I enter the measured values, all of the calculations are performed

Now lets again look at the little "Beaver Baby Grand " Xtal Set for Selectivity.

F test = 600.4 kHz, F low = 543.4 kHz, F test - F low = 57 kHz, 57 kHz x 2 = 114 kHz. This is the Basic or "-3db" Bandwidth. Now "F min" = 434 kHz, F test - F min = 166.4 kHz, 166.4 kHz x 2 = 332.8 kHz = the "-20db" Bandwidth.

As you can see this is not a very selective Xtal set. For the intended use, this was probably not a problem in 1922. In today's world, the Set would be receiving several stations at the same time in almost any city in the US.

Now lets look at the selectivity of the Type SCR-54-A. F test=600 kHz, F low= 589.3 kHz, F min = 556 kHz. This means that the half power or -3db bandwidth is 21.4 kHz and the -20db bandwidth is 88 kHz. With this Set we have the ability to possibility select a station we want to listen to.

BANDWIDTH AT REDUCED SENSITIVITY:

More complex Xtal sets have some means of improving Selectivity at the expense of Sensitivity. There are a number of ways of accomplishing this. In most cases reducing the coupling between the antenna circuit and a second tuned circuit is the method used. This is the purpose of the "Loose or Slide Coupler" that is used in many of the better Xtal Sets. In some Sets changing a coil tap and re-tuning a capacitor will accomplish the change in coupling. It may require some experimenting to find the best adjustment method and control settings for any given Xtal Set. The procedure is as follows;

1. Set up the Signal Generator and the Xtal set the same as in the sensitivity measurement above.

A Slug-Tuned Crystal Radio Circuit Using the Tapped Miller Coil

This is quick to build. The Miller 9011 tapped variable inductor is used. (This tap is 30% up from the cold end.) The end of the smaller portion of the winding is grounded. The other end goes to the stator of a 400pF variable capacitor, the rotor of which is grounded. The antenna goes to the tap. The tap also goes through the diode, then through the earphones to ground, with the earphones being shunted by 0.005uF.

The slug is adjusted to "center" the band in the range of the tuning capacitor. Simpler yet, since the coil is variable, the capacitor can be a fixed one--330pF across the ends of the coil. The only disadvantage is that the range of inductance is only about 4 to 1; since the frequency varies as the square root of this, the frequency range can only be 2 to 1 (from 0.6 to 1.2 mHz, for example).

This set is very loud; however, because the antenna coupling is much too high, it's broad as a hippopotamus. Four stations were received, and only three could be isolated enough to listen to.

A profound improvement can be had by fashioning a coil for the antenna. Wind 20 turns around a plastic bottle cap from a soda bottle (which is 1-1/8 inches in diameter). With bee's wax or cement, fix the cap over the end of the Miller coil. On this new primary winding, the end nearest the open end of the bottle cap is grounded; the other end goes to the antenna.

Wow! With this arrangement, I received eleven stations; eight could be isolated enough to be listened to.

Double-Tuned Crystal Radio Circuit with Slug-Tuned Coils

The coils, one Miller 9001 and one Miller 9011 are mounted near each other on a strip of aluminum. They are pointing the same direction and mounted at 1 inch between centers. (One could make this coupling adjustable by using two strips of aluminum in a scissor-like arrangement, but moving these coils detunes them, so you would have to adjust their slugs each time.)

One end of the 9001 (untapped) coil goes to the antenna; its other end goes to the stator of one section of a dual-ganged variable capacitor. The rotors are grounded. The end of the smaller portion of windings on a Miller 9011 coil (tapped at one-third) is grounded; the other end of this coil goes to the stator of the second variable section. The tap on the 9011 goes through the diode, then through the earphones to ground, with the earphones being shunted by 0.005uF.

Back the slugs out 15 turns from maximum (maximum being all the way in). Check to see if the capacitor tunes the whole band; if not, move the slugs in to shift the stations downward, or move them out to shift every thing upward as necessary. Next, find a station near the top of the band and adjust the secondary (the tapped coil) for maximum volume; retune the capacitor and adjust the slug a second time.

This is the best set I've ever had. It's quite loud, and I can receive thirteen stations, eleven of which can be isolated enough to listen to.

DVM and again adjust the Generator above value of "E1". Keeping the value of "E1" constant removes the output resistance of the Signal Generator and keeps it from effecting the bandwidth to be measured. The higher the resistance or impedance of the Signal Generator the more interaction there will be to obtain the final value frequency at which the Xtal Set output is 0.707 Volts DC. This is because as the Set is tuned to other than the selectivity test frequency the impedance looking into the dummy antenna (the Signal Generator load) changes. >>> Keep the value "E1" constant for this and all of the following tests. <<< Note the frequency. Call this frequency "F low".

2. Subtract "F low" from the Sensitivity test frequency used above. Multiply this difference frequency by two. This value is the basic (half power) "-3db" Bandwidth " of the Xtal Set for comparison purposes. Normally one would measure the frequency above the peak or resonant frequency at which the output also drops to 0.707 Volts and then subtract F low from this frequency to obtain the bandwidth. This measurement was done in this manor because in some cases if you try to increase the frequency to the point where the output voltage drops to 0.707 Volts a number of resonant frequencies of the Xtal Set will prevent obtaining a good measurement. (usually due to self resonance of the Xtal Set coil or coils) The error due to this method is very small.

3. For the next test, reduce the Signal generator frequency until the Xtal Set output voltage decreases to 0.1 VDC. (-20db). Call this frequency "F min"

4. Subtract "F min" from the Sensitivity test frequency above. Multiply this difference frequency by two. This is the "-20db" Bandwidth.

editions of Crystal Clear by Maurice L. Sievers and was described by Alan Douglas in the September 1978 edition of Radio Age.

Test frequency used = 600 kHz. Measured values; E1 = .605 VRMS, E2 = .048 VRMS.

Now the computed values; $I_{in} = .0048$ A, $P_{in} = .0029$ W, $P_{da} = .000576$ W, $P_x = .00233$ W, $P_{out} = .0005$ W, The Xtal Set efficiency = $P_{out} / P_x = 21.48\%$ <<<<<< Now lets add the dummy antenna. $R_x = 101$ Ohms, $P_{best} = .0073$ W then the total efficiency is 6.8%. It is Interesting that there is more energy or power loss in the set but the total efficiency is better by about 4.3 times. This Set has more coils and capacitors which is why the losses are greater but the sets ability to better match the antenna is the reason that the overall efficiency or sensitivity is better. The set is much more selective as will be shown below.

SELECTIVITY or BANDWIDTH:

These tests are a little more complex than the sensitivity tests because selectivity is more complex to define.

Make the sensitivity measurement above and before making any adjustments to the Xtal Set or to the Signal Generator output level make the following measurements. I recommend using a frequency counter to measure the following frequencies.

1. Decrease the Signal Generator frequency to below the first test frequency and until the Xtal set output decreases to 0.707 volts DC (-3db). Readjust the output level from the Signal Generator until the value of Voltage "E1" is the same as that used above. Again adjust the frequency for 0.707 VDC on the

Circuit for the "Rocket Radio"

If you happen to find one of these in a junk shop, they're a lot of fun. They use an untapped slug-tuned coil. Pulling up on the nose of the rocket withdraws the slug and raises the frequency. You will notice the conspicuous lack of the filter capacitor; the capacitance of the crystal earphone doubles as the filter.

One end of the coil goes to the antenna. This junction also goes through the diode, then through the earphone (high-impedance crystal earplug) to the other end of the coil. The earphone is shunted by 220K. Depending on the make, the coil might have enough windings so that the distributed capacitance is the "C" of the LC circuit. Some had a capacitor shunting the coil.

The only ground return is you. The main secret behind these radios was the intimate acoustic coupling from the earphone to your tympanum.

* * *

A Hybrid Crystal Radio Circuit with Lots of Adjustments

The secondary winding is an air-core coil--85 turns of 22-gauge on a 2-inch form; it is multiply tapped and the detector is taken from a 6-position switch. The primary is a Miller 9001 untapped inductor. Since the characteristics of the coils are markedly different, you need separate variable capacitors (of identical type).

The Miller coil is mounted on a sliding bracket that allows its penetration into the cold end of the secondary to be adjusted. A knob is made--having a 4-40 threaded hole--and is fitted to the screw of the slug; a "jam nut" ahead of the knob secures it firmly.

to the negative terminal of a cell, with the positive of the cell going through 100K to the diode's anode.

Selectivity is quite different, a number of definitions are required. The most basic and popular definition of bandwidth is the so-called half power or "-3db" bandwidth. To obtain this number subtract the frequency below the frequency of maximum output where the output decreases to 0.707 times the peak value (F below) from the frequency above the maximum output frequency again where the output decreases to 0.707 times the peak value (F above). Or bandwidth = (F above) minus (F below) In the actual tests below I modify this definition slightly to simplify the measurements.

Selectivity has a second and important characteristic. It is related to Shape Factor. Filters are what make any Radio selective. Unfortunately simple filters are far from perfect. If a filter were perfect the bandwidth would be the same for all values of attenuation. The term Shape Factor refers to a bandwidth at a greater attenuation than -3db. For our tests we will use the bandwidth at -20db for comparing different Xtal Sets. (-20db = E max. x 0.1) & (-3db = E max. x 0.707)

I could also define the out of band selectivity in terms of Filter Skirt Slope (db / octave) but I decided not to go there. I am also not going to talk about circuit quality or "Q" because there seems to be a lot of confusion as to its meaning in overall Xtal Set performance.

Lets Test!!

SENSITIVITY OR EFFICIENCY TESTS:

Finally we are ready to make the Crystal Set Sensitivity or Efficiency measurement as follows;

1. Set the Signal Generator to the first test frequency. (unmodulated)

All Crystal Sets produce a DC output voltage that is proportional to the RF input level and this same proportionality applies to modulated signals producing audio output signals. Proof of this is too long to present here.

Test setup:

Set up the test equipment, the test circuits and the Crystal Set as follows; Connect the output of the unmodulated Signal generator to the 15 Ohm resistor in series with the 200 pF capacitor in series the 20 uH coil. Connect the other end of the coil to the Antenna terminal of the Crystal Set. Connect the low or ground output of the Signal Generator to the 10 Ohm resistor. Connect the other end of the 10 Ohm resistor to the Low or Ground input terminal of the Crystal Set. Note; This Crystal Set terminal is often not in common with (connected to) either of the output terminals. Place the Crystal set on an insulated surface such as a book for RF isolation purposes.

Connect the precision 2000 Ohm resistor across, or in parallel with, the headphone terminals. Connect the 100 kOhm resistor to one of the headphone terminals. Connect the other end of this resistor to one input of the DVM. Connect the other headphone terminal to the other input of the DVM. Connect a .01 uF capacitor in parallel with the DVM. Place the DVM and all DVM leads on a second RF insulated surface like another book.

Replace galena or other diode types with the 1N34 type. I use clip leads.

Test definitions or characteristics definitions:

The only item that I had to define so far were the values for the Dummy antenna. Efficiency by general definition is the ratio of the power output of any device to the power input to it or P_{out} / P_{in} .

DESIGNING AN AIR-CORE INDUCTOR

by Kenneth A. Kuhn

http://www.kennethkuhn.com/students/crystal_radios/designing_inductors.pdf

Introduction

This chapter describes the mathematical process for designing an air-core inductor comprised of a single layer solenoid winding over a rigid coil form. Although the development of the mathematics is a bit complicated the final result is simple to apply. For practical reasons, this chapter will make use of English rather than metric units. A well designed and constructed air-core coil has better performance than those with ferrite cores. Ferrite acts as a flux multiplier and has the advantage that the physical size of the inductor can be reduced. That is very important for small radios and the chief reason ferrite is used. The price paid for small size is loss of performance but that loss is generally negligible in active radios. The loss is not bad for crystal radio performance and many good crystal radios have been built using ferrite core inductors. But ferrite is not required. Purists correctly argue that the coil should be air core as that is how early radios were built. A mediocre ferrite core inductor will work considerably better than a poorly designed air-core one and that has probably led to the popularity of ferrite as the process for designing good air-core inductors is not widely known. This chapter reveals those secrets.

Analytic equation

The classic equation (which you can find in any book or article about winding inductors) for calculating the inductance of a given single layer coil is (Reference 2):

$$L = \frac{r^2 * n^2}{9 * r + 10 * 1} \quad \text{Eq. 1}$$

where:

L = inductance in microhenries

r = coil radius in inches (center of coil to center of conductor)

n = number of turns

l = coil length in inches (center of starting turn to center of ending turn)

This equation is generally accurate to around one percent for inductors of common dimensions. It is more convenient to work with coil diameter and Equation 1 can be written as:

$$L = \frac{d^2 * n^2}{18 * d + 40 * 1} \quad \text{Eq. 2}$$

where d is the coil diameter in inches (center of conductor to center of conductor)

Example: What is the inductance of a coil has a diameter of 2.5 inches, a length of 2.33 inches, and has 72 turns?

$$L = \frac{2.5 * 2.5 * 72 * 72}{18 * 2.5 + 40 * 2.33} = 234 \mu\text{H}$$

Development of design equations

Equations 1 and 2 are fine for determining the inductance of an existing coil but are very awkward to apply to the design of a desired coil as there are many variables. Any time there are a multitude of variables then the possibility of optimum combinations or relations should be explored. In the following development the number of variables is reduced by finding

recommended by the IRE in 1930 for general radio testing. The circuit consists of a 25 Ohm resistor in series with a 200 pF capacitor in series with a 20 uH coil. I split the 25 Ohm resistor into a 15 Ohm resistor and a precision 10 Ohm resistor. The 10 Ohm resistor is connected between the low or ground side of the signal generator output and the input ground terminal of the crystal Set. This was done so that input current to the Crystal Set can be easily measured. The input current is then equal to voltage measured across the 10 Ohm resistor divided by 10.

The second test circuit is the Crystal Set output load that will be used in place of headphones. Headphones all have three values of impedance; the first is simply the DC resistance, the second is the AC impedance at audio frequencies, and the third is the AC impedance at RF frequencies. In order to remove the characteristics of different headphones from the tests I simply replace the headphones with a precision 2,000 Ohm resistor. In these tests I am only interested in measuring the DC output voltage from the Crystal Set so a simple low-pass filter that does not effect the output voltage is added. It is simply a 100 kOhm resistor in series with the DVM and a .01 uF capacitor in parallel with the DVM.

Test frequencies:

The following are the test frequencies to be used. They are 400, 600, 800, 1000, 1200, 1400, and 1600 kHz. Many of the older Crystal sets will not tune to frequencies above 1000 kHz but do as many as the set can tune. This next aspect of the tests may confuse some people. All tests to be conducted are made using an UNMODULATED input signal. This increases the accuracy of the tests and eliminates the need for a Signal Generator that can produce an accurate percentage of modulation. (Most Generators cannot)

Test equipment:

The first item to consider for testing is the test equipment. These tests require three pieces of test equipment; a RF Signal Generator, a RF Voltmeter, and a Digital Multimeter. The Signal Generator should have low output impedance. Most Generators by HP, GR, and others have output impedance of 50 Ohms. When terminated this impedance drops to 25 Ohms. Many so-called Function Generators that have a Sine Wave Output will work just as well for these tests. The impedance does not matter for the sensitivity tests but can be factor in the selectivity tests. The RF Signal generator does not need to have any modulation capability at all. A less common piece of test equipment is the RF Voltmeter. This meter must be able to measure RF voltages from a few milliVolts to over one Volt. A high input impedance of over 10,000 Ohms is also required. A well-calibrated Oscilloscope will meet these requirements but will be less accurate. I use a HP model 3400A RMS Voltmeter. The third piece of test equipment is a battery powered 3-1/2 digit Digital Voltmeter (DVM) or Digital Multimeter (DMM). Everyone that does anything electrical or electronic should have one of these. The DVM must be battery powered to make it RF isolated from ground. Standard diode or diodes need to be used. Some sets use two. I decided to use the popular and common 1N34 type germanium diode.

Test circuits:

The next items are two simple test circuits. The first is the circuit to connect the Signal Generator to the Antenna and Ground terminals of the Crystal Set. This circuit is known as an "Artificial Antenna", "Dummy Antenna", or "Standard Input Circuit". Its purpose is to simulate a typical "Long Wire" or "Marconi" antenna so that the Crystal Set can be tuned in the normal manor. The values chosen to be used are those

relations to known constants. We first replace the coil length by a factor that relates it to the diameter.

$$l = k*d \quad \text{Eq. 3}$$

where

l = coil length in inches

k = a dimensionless constant

d = coil diameter in inches as before

Substituting Equation 3 into Equation 2 gives:

$$L = \frac{d^2*n^2}{18*d + 40*k*d}$$

which reduces to

$$L = \frac{d*n^2}{18 + 40*k} \quad \text{Eq. 4}$$

It can be shown that the value of k that minimizes the length of wire to wind the coil is 0.450. However, other research indicates (see Reference 1) that the value of k that minimizes coil losses is approximately 0.96 even though that value uses about twenty percent more wire. Factors contributing to coil losses include:

- * Ohmic losses in the wire including skin-effect
- * Dielectric losses in the coil form and nearby materials
- * Dielectric losses in the insulation around the wire
- * Induction losses in nearby materials

There are also losses caused by adjacent turns being too close together. It has been found (see Reference 1) that the optimum

spacing (wire center to wire center) of adjacent turns is between about 1.3 to 2.0 times the diameter of the conductor. Coils for crystal radios are commonly wound using what is known as magnet wire (thin enamel insulation) and the turns are tightly wound next to each other corresponding to a spacing factor slightly greater than 1.0 (the thin insulation is of finite thickness). Although it is less than the optimum discussed it works well.

Without some special technique (such as a lathe) it can be very difficult to manually wind a coil with controlled spacing between the turns. One easy method for achieving a spacing factor of 2.0 is to wind two wires tightly side by side at the same time and then remove one of the windings when finished. Smaller spacing factors can be achieved using a smaller diameter wire for the spacer but the difficulty of controlling two wires will increase. It might occur to someone to use a wire with a thicker insulation so that a spacing is naturally formed with a tight winding. The problem with this method is that the insulation may increase dielectric losses and become self defeating –although this may be a small issue –be sure to try it before tossing the concept. This method can work great if Teflon wire is used as that is a very low-loss material and the internal wire strands are silver plated.

Equation 4 can be used to determine the optimum coil diameter for a given inductance and wire size. We note that the coil length is the number of turns divided by t (turns per inch of the wire). We also note that the coil length has previously been related to the coil diameter by the constant, k . Thus:

$$n = k \cdot d \cdot t$$

Eq. 5

Substituting Equation 5 into Equation 4 gives:

CRYSTAL SET TESTING

Charles A Lauter. (email: Lautron@aol.com)

Background:

The following are standards and methods for testing Crystal Sets for the purpose of comparing the performance of different Crystal Sets, Crystal Set circuits, and Crystal Set components in an objective manor. Standards for testing all other types of radios have been in effect since about 1930. Crystal Sets have been in use for almost 100 years but no performance measurement standards exist that I can find. I have read many-many claims of performance for various circuits, coil types, wire types and so on but all without performance numbers that have been measured. There are only two parameters or characteristics of all Crystal Sets that are important. They are the sensitivity or efficiency and the selectivity or bandwidth characteristics. The ability of a Crystal Set to match its antenna is very important and I am including it with the efficiency or sensitivity characteristics. These tests cover Sets designed to tune all or most of the AM broadcast band of frequencies using a standard antenna. More about the antenna below. I am not measuring characteristics such as extended tuning range or the ability to work with very long antennas or any other features not common to most Crystal Sets. In all fairness, these tests were very difficult or impractical to perform back in the 1920s or earlier. Today these tests can be performed with what I consider a modest investment in test equipment. These tests will allow me to compare my collection of Crystal Sets with each other and with other designs of circuits and components. They will also permit comparison with other people's Sets and designs. The reasons for the following test equipment and test circuits will become apparent as the test procedures are followed.

loudness. Similarly, two 3 dB steps would be sensed as "equal" changes in loudness.

$$L = \frac{k^2 t^2 d^3}{18 + 40k} \quad \text{Eq. 6}$$

We will use 0.96 for k and t will be that of the particular wire we have available. Solving Equation 6 for the optimum diameter gives:

$$d_{\text{optimum}} = 4(L/t)^{1/3} \quad \text{Eq. 7}$$

Figure 1 shows a plot of this Equation 7 for common wire sizes. In all cases the turns are close-spaced. The lower curves are for common enamel insulated magnet wire. The two upper curves are for vinyl insulated house wire which can be considered if a large diameter coil form is available. To use the curves, select the desired inductance and the wire size that will be used. Look up the optimum coil form diameter and then use the closest practical form you have to that size. The optimum is broad so do not worry about being exactly on it. Note that the true diameter is the sum of the diameter of the coil form and the diameter of the wire since by definition the coil diameter is measured between opposite centers of the wire.

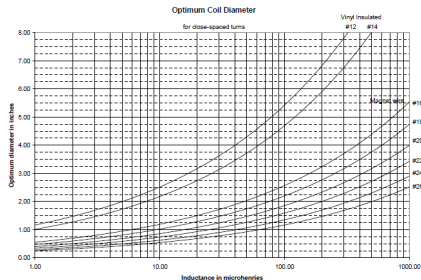

Figure 1: Optimum coil diameter

The following table provides typical values for t (turns per inch) for some common wire sizes:

Table 1: Wire data

Gauge	t	Comments
12	6.2	Vinyl insulated house wire
14	7.7	Vinyl insulated house wire
16	19	Enamel insulated magnet wire
18	24	ditto
20	31	ditto
22	39	ditto
24	50	ditto
26	62	ditto

The length of the winding will be the number of turns divided by the turns per inch of the wire. That is:

know how much better (or worse) a change to it is, and can express it in deciBels (dB). Say that you are taking voltage measurements across a resistor as I do. If the voltage goes from 20 to 40 milliVolts, the ratio of voltages is 2; but wait. Power varies as the square of voltage, so the power ratio is 2 squared, or 4. The logarithm of 4 is 0.6, and 10 times that is 6, or 6 dB. Incidentally, if the measured voltage had gone down from 20 to 10, you would have gone down by 6 dB - it works in both directions. So, all you have to do is divide the larger voltage (or current) by the smaller, square the result (this is your power ratio), and multiply the logarithm of that number by 10 to get the change in dB. Round your answer to the nearest whole number.

If this seems like too much work, here is a short table of common power ratios, the corresponding dB change, and what it means to your ear:

Power ratio	dB	Effect
2	3	barely detectable change
4	6	noticeable
5	7	a little better than 6
10	10	oh yeah
20	13	a smidgen better than 10
100	20	oh yeah again -
200	23	(just to show you the effect of multiplying two numbers by adding their logs)

Note: to the ear, an increase of 10 dB, followed by an increase to 100 dB above the original power level (another 10 dB increase) would be sensed as two equal step increases in

Sony is tuned to just as the cap is closing. That is the minimum f for the LC. More tweaking will determine what f the LC will tune as it is coming fully open. Those 2 f indicate the frequency range of that coil and cap combination.

This will work for MW BCB (midwave broadcast band) using a MW transistor radio, but be sure that the coil on the internal ferrite antenna is parallel with the coil under test.

DECIBELS FOR DUMMIES (how to sound like a tekkie)

The ear is a marvelous device which can process a wide range of noise levels. At a frequency of 1000 Hz, the weakest sound detectable is at a power of about 1 picowatt per square meter, normal speech is about at 1 microwatt, hearing damage starts at about 1 milliwatt (smoky bar with a loud band), and physical pain is felt at 1 watt. Since the ear doesn't respond to absolute power changes in a linear manner, and to cut this trillion to one ratio down to size, we use a logarithmic scale instead. The common logarithm of a number is the exponent or the power to which 10 must be raised in order to obtain the given number. E.g. the logarithm of 100 (10 to the second power) is 2, of 1000 is 3, and so on. Power ratios can be expressed as a logarithm, known as a Bel (after Alexander Graham), but more commonly as a deciBel, obtained by multiplying the logarithm of the power ratio by 10. This gives us a range of hearing loudness from 0 to 120 decibels, relative to the threshold of hearing (1 picowatt per square meter), a much easier, and more useful set of numbers to bandy about. When working with your crystal set, you normally want to

$$l = n/t \quad \text{Eq. 8}$$

We now substitute Equation 8 into Equation 2 and solve for n

$$d^2 * n^2 - 18 * d * L - 40 * (n/t) * L = 0 \quad \text{Eq. 9}$$

$$t^2 * d^2 * n^2 - 40 * L * n - 18 * d * t * L = 0 \quad \text{Eq. 10}$$

Solving for n gives:

$$n = \frac{20 * L + \sqrt{400 * L^2 + 18 * t^2 * d^3 * L}}{t^2 * d^2} \quad \text{Eq. 11}$$

Although a precise value (in inches) for the length of wire required can be calculated using trigonometry for a spiral, a very close value can be calculated as

$$w = \pi * d * n \quad \text{Eq. 12}$$

Remember that d is the sum of the coil form diameter and the diameter of the wire. This approximation assumes that the diameter of the wire is very small in comparison to that of the coil form. Also remember to allow an extra couple of inches for connecting leads at each end of the coil.

Example: A 300 uH coil is needed. The expected Q should be over 350. What coil diameters and wire sizes could possibly meet this?

Solution: Using Figure 2 it can be seen that wire sizes #12, #14, #16, #18, and #20 could achieve the required Q. Using Figure 1 the required coil form diameters are:

Optimum

Gauge	diameter
#12	7.75"
#14	6.75"
#16	3.75"
#18	3.15"
#20	2.65"

A piece of 4.5" OD PVC pipe is available and #14 electrical wire is available. From Table 1, #14 insulated wire will make about 7.7 turns per inch. Thus, the effective diameter is 4.5 plus $1/7.7 = 4.63$ inches. Using Equation 11 the number of turns required is 86. Using Equation 8 the length of the winding is 11.2 inches. The length/diameter ratio is 2.4 which is a bit longer than the optimum of 0.96. The length of wire required is given by Equation 12 and is 1,251 inches. The length would have been 1,058 inches if the optimal diameter could have been used. This extra length will cause somewhat higher losses –it might still meet the desired spec though. This is about as far as I would go in rounding to an available coil form diameter.

Estimation of Inductor Q

All inductors have an equivalent series resistance loss as discussed earlier and is comprised of a number of components. We measure the quality factor or Q of the inductor by computing the ratio of inductive reactance at the frequency of interest to the series loss resistance as follows:

$$Q = \frac{X_L}{R_s} \quad \text{Eq. 13}$$

where
Q is the dimensionless "quality" factor of the inductor

resonant frequency of your coils. If your coil has a lot of self capacitance, it will show a dip at a lower frequency somewhere in the HF region than one that has little self capacitance. I found the oscillator particularly useful when working with short wave xtal sets. It allows you to check the tuning range of your tank circuit with enough accuracy to put you into a favorite short wave band. It really came in handy when trying to figure out the details of a shortwave antenna tuner. By coupling the dipper loosely to the tank coil of the tuner, you can check the resonant frequency of the antenna/tuner combination. It seems that with the short wave bands, your favorite xtal set antenna is actually longer than a quarter wavelength, and tuning it to a band can be somewhat tricky. The GDO helped me get the antenna to resonance.

Here is another testing gimmick courtesy of Steve Holden:

Unless you are following somebody else's plan to the letter and using all parts that are exactly the same as he had, there will always be some "cut and try" to be done during the "breadboard" stage. Since all of my electronic test equipment combined would fit in a shoebox I use a few tricks that Pros would not use. For example if I want to find out what f range a coil and cap will tune I use a Sony shirt pocket SW (short wave) radio. I turn the tuning of the Sony to an open spot in the f range I think the LC will tune, then, with whip not extended and the radio volume set to hear noise softly, I place the LC under test near the whip and turn the varicap. If I guessed right, at some point the volume from the Sony will come up. This is because the LC circuit is functioning as a tuned loop antenna. Some more experimenting will allow me to determine what f the

Another useful piece of test equipment, also excellent for chasing dx stations, is a receiver with a digital frequency readout. My Radio Shack set, a pocket portable, fits the bill and costs about 50 bucks or so, depending on how the sales are running. It tunes in 10 kHz increments on the AM band, and I am confident the actual frequency is accurate to within a hundred Hz or less. You can use this to check the output of your sig gen, and to check its frequency; your less expensive and older signal generators have analog tuning and readout, and their calibration can be suspect. It also can be used to calibrate the dial of your crystal set in conjunction with the signal generator to at least the accuracy of a standard analog pocket superhet. You might consider this last to be gilding the lily, but having a known "dial marker " or two can keep you oriented when you're searching the dial.

A meter capable of inductance and capacitance measurements is nice to have, and I use a friend's whenever I make a new coil or want to check an unknown capacitor. Haven't seen fit to spring for one myself however. If I need to, I can always check the inductance of a new coil using a known capacitance with it in a tank circuit and the signal generator. Q meters? They're out of my league, so I depend on the kindness of strangers to tell me how to optimize coil Q.

I recently acquired a Heathkit grid dip oscillator, and found it to be a useful tool, even though its frequency range starts at 1.5 MHz. Actually, it produced harmonics, or probably parasitic oscillations into the BC band, but isn't calibrated for them; I should probably wind a plug in coil just for the BC band, but that's for another day. So what can you do with one of these? Well, you can start by using it to check for the

XL is the inductive reactance in ohms at the frequency of interest

Rs is the equivalent series resistance in ohms at the frequency of interest

Note that inductive reactance, XL, is calculated as

$$XL = 2 * \pi * F * L$$

where

F is the frequency in Hz

L is the inductance in henries

The equivalent series resistance is the net of ohmic losses including skin effect, dielectric losses in distributed capacitance and coil structure, absorption losses by nearby conducting media, magnetic losses in nearby magnetic media, etc. With care these losses can be kept small but it takes very little loss to reduce the Q of an inductor from 400 to 200. The magnitude of Rs can be measured on sophisticated impedance equipment but it is hard to calculate the effect of all factors. Figure 2 shows an estimated value of Q at 1 MHz considering typical losses assuming the coil is wound optimally and is not disturbed by nearby lossy materials. Use the figure only as a guideline as your specific results may be better or worse. The expected Q at 540 kHz will be between about 50 to 70 percent of what is shown and the expected Q at 1.6 MHz will be around 1.2 to 1.5 times that shown.

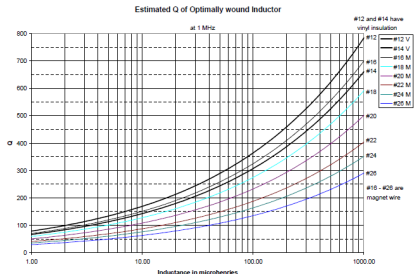

Figure 2: Estimated Q of Inductor

The Q we obtain from Equation 11 is for the unloaded coil (i.e. antenna and crystal detector not connected). The net loaded Q will typically be significantly smaller but ideally (as discussed in another chapter) would be in the general range of one hundred. Thus, we would like to start with an unloaded Q of several hundred. As can be seen in Figure 2 the Q of the inductor can be made higher by using larger diameter wire. From Figure 1 this also means using a large diameter coil form. This is a very important conclusion –high Q coils need to be physically large.

Type of wire

The only material to consider for the wire is copper. A variety of styles of copper wire is readily available. The most basic choice is between solid or stranded. Although a variety of arguments can be made for and against each, in practical terms you will not notice any difference in performance although one

hobby, and if I can have this much fun with a handful of cheap parts and some 20 year old, bottom of the line test equipment, working on a table set up in the laundry room, so be it. I have tried to use my "super convertible" as an rf signal generator in the regeneration mode, and it works pretty well. Just put a 2k resistor in place of the headphones, and you can use it as a nice, unmodulated signal. Yeah, it drifts some, but as long as you don't have an antenna hooked up to it, it's pretty stable. Shouldn't be too hard to couple a one transistor audio oscillator to it for some modulation. Transtronics sells their [RF Signal Generator SK-303](#) kit for about 28 bucks. Maybe I should give it a try.

The multimeter connected across your earplug resistor also is most useful in comparing different detectors. What you are usually seeking is the best sensitivity, so first find a weak but stable station (or detune your set to make one), which gives you about 10 mV or so across the resistor (I use this value with the 47kohm resistor). Then you can readily compare different detectors by swapping them in and out of the circuit. With a digital voltmeter with readouts to the nearest 0.1 millivolts, go for a reading of about 2 mV with the station very weak but still clear. This goes faster if you use a couple of alligator clip leads for the connection. In a 10-pack of 1N34A diodes, I have found the voltage developed across the diode to vary as much as 30%; at this level, that equates to about a 2 to 3 dB difference in signal strength, even though the audible difference is small. For stronger signals, the difference in detector sensitivity is less, but doesn't matter.

Use the same setup to check out the effectiveness of your wave traps when you're cutting how the high powered stations.

the BC band, where the antenna tuner coil alone improved the signal from a 135 foot antenna by as much as 12 dB. When I put it on my Radio Shack crystal set, after first adding the obligatory 47 kohm resistor across the earphone, I found the sensitivity for it and my selective crystal set to be within a few millivolts of each other. The list of what you can do from this point is long enough to keep you busy for hours on end. One use that I also found very useful is to compare the sensitivity of different detectors; sometimes within a batch you can see differences of as much as 10 dB. On to phase 3:

For this part, you need an rf signal with some audio modulation. I happened to find an ancient but usable rf signal generator in my school lab which fit the bill. It has to be variable in frequency, and you need some way to check its output frequency, because we are going to try to measure the selectivity of your set. I put the output of the generator across the antenna coil of the selective crystal set, and adjusted the signal to a comfortable level on the voltmeter described above, about 50 mV. Then I adjusted the signal frequency up and down by 25 kHz and 50 kHz, and measured the signal output across the earphone. From a center frequency of 1100 kHz, the signal strength dropped by 12 dB at 25 kHz off, and by 20 dB at 50 kHz off. Running the same test on the Radio Shack set, the change was 2 dB and 5 dB, respectively. I don't know if my set is really any good since I haven't done much comparison testing, but compared to it, the RS kit selectivity sucks. For both rigs, selectivity improved some at lower frequencies, and was a bit worse at the top of the band. At this point, some electronic engineer type is probably reading this and shouting obscenities at his monitor for my sloppy, unsophisticated, and jerry built methods. Well, this isn't Nature magazine and I'm not trying to sell cold fusion. It's a

or the other may have physical advantages for your particular construction method. Avoid wires that are plated as those will have higher losses since skin-effect will cause most of the conduction to be in the plating which has higher resistance than copper. Avoid wires with rubber or cheap plastic insulations as dielectric losses will be higher. An exception is silver plated Teflon wire as that has the best conductivity and the lowest dielectric losses –but it is expensive.

For use in low to medium frequency inductors there is a special wire called Litzengrad or just Litz for short. It is designed to minimize skin-effect losses and is made by assembling many strands of enamel insulated magnet wire together to form a wire that has a large surface area. Litz wire is not easy to find and tends to be expensive. If you are going to use Litz wire then make sure that other losses as previously discussed are minimized. Otherwise Litz wire will make little if any difference and will be wasted effort and expense. Avoid belief in a variety of myths about skin-effect. Although it is true that skin-effect is more severe on large diameter conductors, a larger diameter still conducts better than a smaller diameter at any frequency. This can be seen in Figure 3 which shows the frequency dependence of the resistance per meter factor of some common wire sizes.

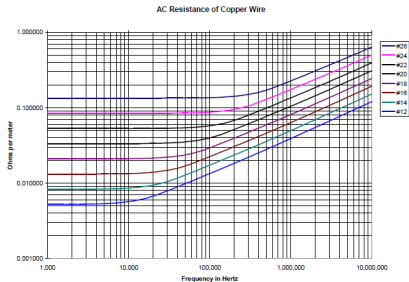

Figure 3: AC Resistance of Copper Wire

Coil Forms

From a loss standpoint air is the best coil form material there is. The obvious problem is that air has no structural strength. However, there are methods used by commercial inductor companies that employ a minimal structure so that the coil form is around 99 percent air. Manually, you can achieve the effect by first winding the coil using large diameter solid copper wire (i.e. #18, #16, #14, etc.) on a rigid coil form and then carefully sliding the winding off of the form. The stiff wire will retain the shape and you can easily space the turns to the optimal discussed previously. You will need a few supports to keep the whole thing from being too loose.

A popular coil form is some kind of cardboard tube that you have salvaged from a variety of sources such as used for paper towels or shipping tubes. These are great if you are using small diameter wire as small wire will not self support. Plastic pipe

with it? First, and obviously, you can use it to tune a station for the best signal. On a strong station, you will be amazed at how much the signal strength can vary and it not make a heck of a lot of difference in earphone volume. This is because the ear is a marvelous signal processor itself, and can accommodate a range of loudness, or signal power to the ear of 90 decibels, that's ten to the ninth power, otherwise known as a billion to one between the softest whisper it can detect and the point at which the ear starts to suffer damage with chronic exposure. Multiply that loudest sound by another thousand, you are now at a trillion to one, and the sound is so loud that it can cause physical pain. In order to handle this range of signal power, the response of the ear is logarithmic, and the power of a sound has to change by a factor of two for you to readily detect it. Since power varies as the square of voltage, this means you usually need to see a forty percent change in voltage, or about a 3 dB change in power to notice the difference in loudness. The voltmeter, being more responsive than the ear to small changes, can help you fine tune to a station, and then compare the difference in signal strengths from different stations using a number rather than an impression. Once you have played around with this a bit, it's on to phase two:

Now that you have a signal strength meter, you can start using it to optimize the settings on your rig. Using it on a receiver similar to Radio number four, which you can find on my [project](#) page, I found that the optimum tap for sensitivity and selectivity was at about 35 percent of the coil from the ground end. The 20 turn tap for the detector (for sharp tuning) showed a 9 dB loss of signal strength compared to the best tap, while giving less than a 2 dB gain in selectivity. As expected, using an antenna tuner helped, particularly in the low end of

seriously load down the circuit. The digital multimeter has a virtually imperceptible effect on the signal. I tried once putting a galvanometer with a 50 uA movement in line between the detector and the earphone but the reading, which was only about 4 uA, as expected, wasn't enough to make this useful, being at the very bottom of the scale. Anyway, for my money, the high impedance voltmeter makes a much more useful tuning indicator.

If you are using magnetic headphones, which don't have the 47k resistor across them, you will not get much of an indication on the meter. Just put a 47k or some other reasonably high value resistor in series with the headphones and measure the voltage across it - yeah, the resistor cuts your signal a tad, but you're only putting it in long enough to sharpen up the rig's tuning anyway. Incidentally, there is nothing magic about the size of the resistor; I just happen to have several on hand. If you use a larger resistor, you will get a higher reading on the voltmeter, but will also have a corresponding smaller signal in your magnetic headphones. Use the smallest resistor that gives you a usable reading on the meter - this is not an absolute signal level you are measuring, but rather a tuning aid. Just to see what I could do, I tried out a cheap multimeter with a 1000 ohms/volt meter sensitivity. If I tuned in a reasonably strong station, and just put the meter in place of the 47k resistor, I could indicate enough level on the 2.5V scale, in the neighborhood of 200 mV or so, to make some use of the meter. This is pretty low on the scale, but still enough to see the effects of tuning the rig.

Okay, so now you have a tuning indicator/signal level indicator or whatever you want to call it. What can you do

is another material you might consider. None of these materials are made with any consideration about high frequency dielectric losses but because only a small amount of material is used the losses are probably minimal.

Wood is a convenient coil form and has low losses if very dry. Common sizes that have been used are 2x2, 4x4, or a pair of 2x4 combined to make 4x4. Round dowel rods may also be used but their diameters are often much less than optimum. When using a square coil form there is a logical question about how that affects the inductance calculations. A simplistic (but good) answer is to use an effective circle diameter that has the same area as the square form since area is a strong factor in inductance. Losses with a square form will be somewhat higher than for a circular form. Rectangular forms (such as a single 2x4) have even higher losses in comparison -it takes more wire to encompass a given area.

Winding the coil

Counting turns is a tedious and error prone task. It is much simpler to cut the length of wire needed and then wind that until finished. The resulting turns count will be very close if not exact. Wire is springy and will jump off the form in a tangled mess if not restrained. Start by securing the wire at one end of the form and have a means for easily (preferably with one hand) securing the opposite end when you finish. It is tempting to use some kind of adhesive tape and that will work if you are careful and understand what you are doing. The forces will build and the tape may give way which will result in a frustrating mess of tangled wire. Make sure the tape can not slip. A good way to secure the ends is to first drill a hole in the tube at the starting and end points. Then feed the starting end through the starting hole and bend the wire such that it naturally resists tension and secure the wire with tape. Stuff the

loose end length inside the tube so it is out of the way while winding.

It is best to wind the coil by hand as the set up for using a lathe is not worth the trouble for a single coil. There are a number of "poor man's" lathes such as a power drill that have been used but I do not recommend that as you are more likely to make a mess or cause injury than you are to wind a coil. It only takes a couple of minutes to wind a coil by hand so take the time to think what you are doing. It is important to keep the winding tight at all times. The wire will spring off if it ever gets loose. You will very likely have some fractional turn as a result of your calculations. I recommend that you round that to the nearest integer as it is not worth the trouble of making measurements to stop at a specific fractional turn.

References:

1. Electronic and Radio Engineering, fourth edition, Frederick Emmons Terman, McGraw-Hill Book Company, 1955, pages 30 – 33.
2. The Radio Amateur's Handbook, 44th edition, 1967, The American Radio Relay League, Newington, Conn., page 26

TESTING YOUR CRYSTAL SET

(22 Nov 01)

Owen Poole

<http://bellsouthpwp2.net/w/u/wuggy/testing.htm>

If you like to fiddle around with your crystal sets, then you need some way to do comparisons of before and after when you want to try something new. Of course, the obvious is to listen. If it sounds louder, it is. If you don't hear the other station that is close in frequency any more, then selectivity is better. If you hear everything you want, then your set is working fine, and you need go no further. If you are trying to push it a bit, however, some reasonably objective yet quantitative measurements are helpful for you to optimize your set and to compare the performance of different sets, antennas, modifications, etc. Here are a couple of things I do with my rigs:

Get a DC voltmeter which will measure small voltages in the millivolt range. I use either a digital multimeter or a RS analog multimeter with about 20 thousand ohms per volt sensitivity (less sensitive meters will load down the circuit unacceptably, and will probably not measure down in the millivolt range, but go ahead and try if you have to). The RS analog model I have has a 0.6 VDC (600 millivolts) scale which works pretty well. I then connect the meter across the 47 kohm resistor which is also across the crystal earphone. Using this setup, my closest local BC station, less than a kw about 6 miles away, gives me a reading of about 190 millivolts. A station with a 50 kw daytime signal about 75 miles distant comes in at about 30 mV. With the analog meter, there is a little insertion loss, about 10 mV, but not enough to

ANTENNA MATCHING

by Kenneth A. Kuhn

http://www.kennethkuhn.com/students/crystal_radios/antenna_matching.pdf

As discussed in an earlier chapter the ten to thirty meter antenna used for crystal radios has a very low resistance and a high capacitive reactance. The ground resistance discussed previously is typically in the several tens of ohms and is effectively in series with the antenna. As an example, an antenna/ground system may have an impedance of $20 -j1000$ ohms at 1 MHz. For maximum power transfer from the antenna to the resonant circuit the input impedance of the set should be a conjugate match –that is have similar resistance but the reactance will be equal in magnitude but opposite in sign. For the example this means that the crystal set should have an input resistance of about 20 ohms and a reactance of about $+j1000$ ohms (160 μ H) at 1 MHz. The positive reactance is obtained by an inductance in series with the antenna circuit. This inductance should be variable to tune out the capacitive reactance of the antenna across the AM broadcast band. Tuning is not sharp as the Q of resonance is low. Table 1 shows some typical values. Note that the inductance tuning range becomes wider for longer antennas since the capacitive reactance drops rapidly as the length approaches one-quarter wavelength at the upper end of the AM band. It is important that this series inductance have very low losses or the advantage of using it will vanish –a lossy inductor could be worse than nothing.

Antenna Length	Typical Antenna XC @ 550 kHz	Typical Antenna XC @ 1.7 MHz	Antenna series Inductor tuning range
10 m -	j4040 ohms -	j1250 ohms	1200 – 120 uH
15 -	j2680 -	j780	780 – 70
20 -	j1990 -	j530	580 – 50
25 -	j1580 -	j360	460 – 30
30 -	j1290 -	j240	370 – 20

Table 1: Antenna series inductance tuning range

One effect of not tuning out the reactance of the antenna is that the resonant frequency of the tuned circuit will shift because the antenna becomes a reactive load. One way to know if the series inductance has been tuned to the right value is that the station is received at the calibration point –assuming the radio tuning was calibrated.

The next issue is creating a low input impedance of several tens of ohms. There are two ways to do this and they are essentially the same. One method is wind a turn or so of wire near the ground end of the coil of resonant circuit –one end of the wire goes to the series inductor to the antenna and the other end connects to ground. This small winding transforms the low antenna/ground impedance to a high impedance across the coil. The other method is to make a tap a turn or so above the ground end of the coil of the resonant circuit to accomplish the same effect. If the winding or tap is too few turns then there is an impedance mismatch and a weak signal will result although selectivity will be relatively sharp. If the winding or tap has too many turns then the coil is overloaded by the antenna/ground impedance which also results in weak signals and the selectivity will be broad. The optimum is the point of



Lyonodyne 17

Special Thanks to:
Mike Tuggle

L1 51 turns 100/44 litz on 5/8" dia. x 1-3/16" long ferrite rod,
u(eff) = 10.33;
length = 1-35/64"; L = 146.6 uH; Co = 4.54 pF; Q @ 0.5 MHz
= 649

L2 36 turns 660/46 litz, basket-wound over-1, under-1 on 5"
dia. 13-point form;
length = 1.9375"; L = 185.6 uH; Co = 7.40 pF; Q @ 0.8 MHz
= 1134

L3 36 turns 660/46 litz, basket-wound over-1, under-1 on 5"
dia. 13-point form;
length = 1.9375"; L = 185.7 uH; Co = 7.40 pF; Q @ 0.8 MHz
= 1060

L4 42 turns 660/46 litz, basket-wound over-1, under-1 on 4-
1/4" dia. 13-point form; length = 2.25". L= 186.7 uH; Co =
6.45 pF; Q @ 0.8 MHz = 1082

R1 500 k-ohm pot.

S1 DPDT miniature toggle

T1 UTC A-27: input transformer --100 k-ohm primary;
secondary taps, 50 to 600 ohms -- around 200 ohms seems best
with the RCA phones below.

PHONES: RCA MI-2045 sound powered phones, known as
"Big Cans" in the trade.

All variable capacitors have vernier drive dials.

proper impedance match although it is not very critical. The
issue is how to determine the proper point. A second issue is
that the required impedance level varies across the AM
broadcast band. Thus, the tap should be variable.

If the coil is wound on a ferrite toroid core which enables a
high degree of flux coupling from turn to turn then it is fairly
easy to calculate at what turn a tap should be for the desired
impedance transformation. However, our coil is typically an
air-core solenoid which has a complicated flux relationship.
Calculation is difficult and very error prone. The best way is to
make a variety of taps and measure the impedance using
laboratory methods and note the results. I will present the data
of just such an experiment on a typical coil for crystal radios
when this article continues ...

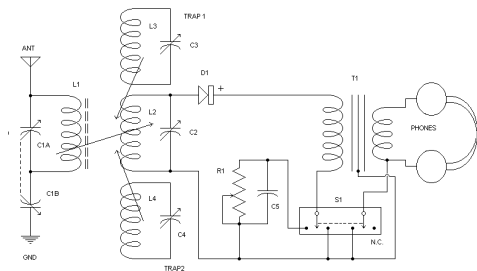

Lyonodyne-17 Parts (as of 2/5/01)

C1 two gang, 15-470 pF per gang, variable capacitor, high parallel leakage resistance, Rp.

C2 R/C (or TRW) 15-497 pF straight line frequency variable capacitor, Rp on the order of 20 megohms. No. 107-C-522; FSN 5910-546-9239. Fair Radio Sales cat. no. C123/URM125

C3 same as C2.

C4 same as C2.

C5 0.02 uF polystyrene.

D1 selected (by listening) Radio Shack 12101 3RT germanium diode.

took out the tree at the other end. The shorter flat top worked so well I brought it here to Hawaii, where real estate for long antennas is at a premium. It's about all I can fit gracefully onto this lot. Ground is tapped directly into the city water system.

Circuit Details

The antenna-ground system is tuned by the primary, L1-C1, and is coupled to the secondary, L2-C2, via loose L1 - L2 coupling (physical distance 3 to 4"). L1 and L2 are positioned radially (side-to-side), while the coils of two QRM traps (high-Q, parallel L-C cks.) are coupled axially to L2. L1 has virtually no effect on L2-C2 tuning and Q, but the QRM traps do affect tuning, especially near the QRM frequencies. So, their coupling is kept to the minimum which will still allow reception of the stations of interest. The set is capable of receiving stations on frequencies adjacent to murderous locals. The low-Z sound-powered phones are impedance-matched to the secondary tank, L2-C2, and detector with a UTC A-27 100 k-ohm-to-200 ohm input transformer. The single 12101 diode detector is estimated to present about 200 k-ohm resistance in the forward direction. These impedances, in series, allow you to place the detector-phones directly across the tuned circuit without undue loading. Taps, used in the past, are a mess -- especially with litz wire. Further, they kill a coil's Q, and are to be avoided if at all possible.

VARIATIONS ON A SLIDER-TUNED SET

Owen Poole

<http://bellsouthpwp2.net/w/u/wuggy/slider.htm>

My first crystal set used a prewound coil, a slider for tuning, a catwhisker and galena crystal, and had a large square mica capacitor (remember those?) across the headphone terminals, feeding a single 1000 ohm headphone. For a variety of reasons, which I don't remember 40 plus years later, it only got one or two stations in Atlanta, GA, but, even at that, it was still magic. Back in an era when responsible parents believed children should remain at least one economic level below their parents, having a radio of any type in my room was doing pretty well, and life was good. This type of set is tricky to use, since maintaining contact between the coil and the slider is touchy, and then you have to find a good spot on the galena crystal with the catwhisker, also easily knocked out of adjustment. Still, it has its advantages; it's inexpensive and it works. The headphone was a cost driver, and throwing in a variable capacitor could easily double the cost. A step up on the ladder came when AM tuning coils with slug-tuned ferrite cores came on the market, which were used in the tank circuit with a fixed capacitor, and feeding a germanium diode. I had a "pocket" receiver which had these as well as a pretty sensitive earphone which was built into the case.

About a year and a half ago I had a nostalgia fit and built another slider, but used a crystal earplug, a 1N34, and even added a 365 pF variable capacitor, remembering the tricky slide contact problem, but wanting to be able to vary the L/C ratio over a range of frequencies. The set worked pretty well, but lacked selectivity. This is a drawing of the set:

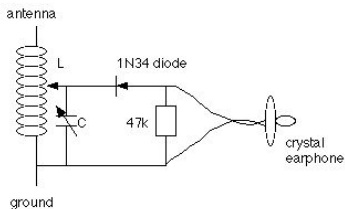

I found that the best place to connect the antenna and ground depended on the antenna used and probably on local conditions. Sometimes connecting the antenna to the slider worked well. I tried the detector tap at the top of the coil, as some designs do, but selectivity really suffered. Some selectivity improvement was seen when I wound a smaller coil for an antenna loading coil and put it up inside the tuning coil. Again, you can still play with where the antenna and ground are connected; you can put the antenna or ground to the loading coil, and try the other on either end of the tuning coil or on the detector connection. You can also make your earth ground to both the loading coil and the tuning coil. The best arrangement is what works best for you. An operating benefit of connecting the detector to the slider is that you don't hear anything unless the slider is making contact with the coil.

(3) if necessary, pad the variable capacitors with high-quality air trimmers to get to lowest frequency and spread out top-end tuning

(4) choose coil design which peaks in Q in the central BCB range -- operating near the self-resonant frequency is self-defeating

Superior quality tuning capacitors (silver plated with ceramic standoffs) were used in the present version. The two prime tuning capacitor candidates I had were a 500 pF and a dual, 470 pF per gang, both silver-plate, ceramic insulated. (Typical parallel leakage resistance measurements on these were 20 megohms, by the Boonton 260-A.) Accordingly, the set was designed about them.

I credit Bill Bowers of Oklahoma with exposing me to the virtues of finer-strand litz for medium frequencies, the use of larger coil diameter-to-length ratios (ca. 5-to-1) than theory suggests, and for going back to 'over-1, under-1' winding pattern. They are not as pretty and have lower L's than the same-sized 'over-2, under-1's', which I used for many years, but they do have substantially higher Q's.

And credit to Al Klase for preaching the virtues of sound-powered phones long enough and loud enough that I finally had to listen -- despite my being firmly convinced nothing could ever surpass Brush crystal phones. The sound-powered's are a real ear-opener, literally, and an order-of-magnitude improvement.

Antenna has been, for some time, a 50-foot, 4-wire flat top (wires spaced 1 ft. apart), maybe 25 feet high. At my previous location, I used to have a 105-ft. long-wire, but high winds

Summary

The "Lyonodyne-17" is a much-advanced version in a series of DX crystal sets evolving from circa 1974. I've been particularly interested in crystal sets since 1959, when I first discovered you could actually DX with them. It's a completely passive set -- no amps, no bias on the detector. The circuit is double-tuned and uses super-high quality components: silver-plated variable capacitors and high-Q litz wire basket-wound coils. Isolated coil Qs are in the 700s across the BCB and over 1000 for much of the BCB. In-set Qs are less, of course. Phones are high quality, surplus sound powered ("balanced armature") units, matched to the high-Z secondary tank/detector by a high quality line transformer. Detector is a single 12101 3RT, sold by Radio Shack as a "1N34 Type." It's the best I've found so far. With traps and all, it takes up the better part of a desk top.

Description

After several abject experimental failures, I concluded that the magical "high L-to-C ratio" for tuned circuits is a crock -- in spite of what theory might suggest. That, and the high Qs obtained in 200/44 litz wire (now, 660/46) coils got me to re-thinking my set's design and construction. This led to a completely rebuilt crystal set -- same circuit, but redesigned components per the following principles:

- (1) design for the lowest L/C ratio as practical
- (2) use highest quality variable capacitors available

My latest design attempt, which shows promise in the breadboard stage, goes back to a fixed capacitor in the tank circuit, but incorporates an antenna loading coil and separate detector taps, two features which I consider essential to selectivity in a single tuned set. The drawing for this rig is shown below:

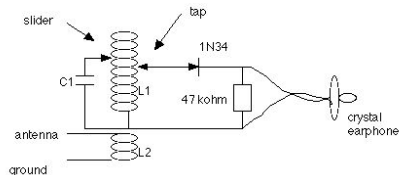

My coil was 100 turns of #26 magnet wire close-wound on a toilet paper core, with detector taps at 10, 20, and 30 turns from the bottom (connected) end. The antenna coil, L2, is 15 turns of #26, also on a tp core. I chose to separate the coils so I could move the antenna coil about to vary coupling, but could probably have done about as well winding both coils on the same core with about a 1/8 to 1/4 inch separation between them. Note: I found that the loading coil had to be placed at the bottom end of L1 as shown; placing it at the open end didn't work very well at all (for me). For a slider, I just straightened out a large paper clip, soldered it with a stranded hookup wire into a soldering lug, and then used a wood screw to hold the slider to the base I used. Just for grins I rolled my own fixed capacitor, C1, making it about 300pF.

On the air results were pretty good. The detector tap is selected by an alligator clip. I got the separation I wanted between the two strong locals that are 50 kHz apart, sensitivity is ok, BUT, the rig design still needs some work before I offer it to my students. Current problems and possible solutions: a). Only using about half the coil, and it tunes pretty fast - use larger wire, maybe a smaller diameter coil form, and maybe a smaller value capacitor. (probably do at least two of the three)

b). Not happy with the paper clip slider; too flexible so you get backlash, and doesn't ride smoothly - use a metal strip and maybe add another washer where it connects to the base.

c). With detector tapped directly to the coil, you always hear something, whether or not the slider is making contact. I guess I can live with this.

Lyonodyne Version 17 Crystal Set

from Mike Tuggle

<http://www.crystalradio.net/crystalsets/lyonodyne/index.shtml>

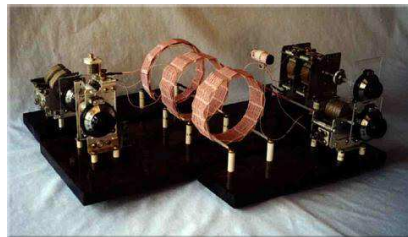

Builder and Operator Mike Tuggle

The "Lyonodyne-17" is an advanced DX crystal set evolving over the years. It was a first place winner of the DX "Open Class" contest two years in a row in 2000 and 2001. Mike placed second in 2003 after handicapping himself by using a rock (lead telluride) as the detectors. The radio incorporates the "Tuggle" front end (which will be shown later), and very high quality parts.

Note:

This is not intended as a "How To" article for a beginner. The following is supplied as information only. Some of the techniques used in the construction of this radio are very advanced and not recommended for a beginner or even an intermediate builder.

My own experiences over the years have led me to shed my skepticism of the incredible DX reports made by old-timers back in the early days. Component technology was not what it is today, but circuit technology was, and the sparsely populated bands back then had to be a lot more DX-friendly. You may want to pull an antique crystal set off the shelf and give it a spin. I'd encourage it.

Some of these old sets are extremely well built. The construction of the military BC-14A/SCR-65 never ceases to amaze me--and others were built just as well. But to start out, I'd recommend conceding to modern technology by using a good, modern diode and sound-powered phones with matching transformer. With just a little luck, prepare to be amazed all over again!

A CRYSTAL RADIO WAVE TRAP

Owen Poole

<http://bellsouthpwp2.net/w/u/wuggy/traps.htm>

This is a little circuit that is a real giant killer when you are trying to nose up to a loud local to look for the little guys. Basically, it is a tuned circuit placed in the antenna path to your rig, which traps and then dissipates the signal, or at least a bunch of it, from a station, allowing you to reduce interference between stations. There is nothing fancy to it, but a little care in construction and operation can make it really work well. Here is one of mine:

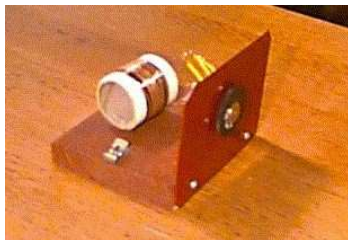

I used a 1 1/4 inch diameter cardboard core, and wrapped 100 turns of #32 enameled wire around it, closely spaced, and attached the ends of the coil to a 200 pF variable capacitor. This forms the tank circuit. I also wound over the first coil a second one, using 15 turns of #22 enameled wire, and ran each

end to fahnstock clips - the antenna is connected to one clip, and the second goes to the antenna tuner, the set, or what have you. To use, just tune your receiver to the offending station, and then adjust the trap's capacitor until it reduces the signal. About 15 seconds is all the time you need to become a pro. The #32 wire, being of relatively high resistance, dissipates the signal that makes the tank circuit resonate (real engineers have assured me this is a bunch of baloney, and they are probably right, but my little trap works fine for all that - smart money says to make it of larger wire). . The #22 wire transfers the signal inductively from the antenna circuit while offering a low resistance path for other frequencies. It tunes fairly sharply, so tune slowly. You could install a bypass switch for times when the trap isn't needed, but I just tune to trap out of the way, with no signal loss to that I can notice. If you have more than one station you want to knock out at the same time, put more traps in series with this one. I have two which I use to cut out the two strong signals from two stations dominating the top of the band only 50 kHz apart. They are still too close together to listen between them, but I can certainly get much closer above and below them now. I might try a few more turns on the smaller coil to see if it sharpens up the signal a little. This was a first attempt, and I haven't tried to optimize it. Had I wound the coil for about 400 uH, I could have gotten full band coverage - actually, in my QTH, there are no loud ones below about 690 kHz, so this setup works fine for me with the 200 pF capacitor.

While you are winding the 100 turn coil, go ahead and put a tap in it, say at 30 turns or so. Then you can use the trap for a crystal set as well by adding a detector and earphones across the 30 turns. This lets you do at least two things: 1. It is a nice little crystal set all by itself. 2. You can operate it as a

closest some 2400 miles away? As it turns out, Hawaii is an ideal DX location--for distance if not for sheer numbers of stations. With no regional stations, sunrise-sunset activity is non-existent.

West coast 500-watt stations, 2500 miles distant, have been heard here. High-power stations in Cuba (4800 mi.) and the Caicos Islands (5500 mi.) have also been heard, thanks to a mostly water path. Stations from the "interior" also make it over. Last year, it was neat to hear KRVN in snowbound Nebraska (3600 mi.) using a homemade cat's whisker mineral detector. This must be what it was like in the old days.

With low station powers and crowding, medium-wave broadcast band DXing represents the greatest challenge. On short wave there's no limit to the distance--reception is truly worldwide. I occasionally hear the South African broadcasts nearly 12,000 miles away; Johannesburg and Hawaii are nearly at antipodes. From the mainland, Australia (11,000 miles) was a routine catch. Figures 5 and 6 show my "12,000-mile" crystal set.

Crystal Set DX Activities

Crystal set DX activities include discussion forums sharing ideas and results, an annual DX listening contest now into its sixth year, and the occasional set-building contest where some remarkably high-caliber craftsmanship comes to the fore. All of these activities are served up on the Internet.

The following site is a highly recommended grand portal to the wonderful world of crystal set DXing: Owen Pool's Crystal Radio Resources at <http://www.thebest.net/wuggy>. The comprehensive set of links here covers all aspects of the hobby. This site is headquarters for the annual crystal set DX (XSDX) contests open to everyone. The contest usually takes place in late January. Watch for announcement of specific dates and rules.

antenna. The rule of thumb is, if you can hear them on a radio, you can hear them on a crystal set.

The best times to listen are at sunrise and sunset, when stations are signing on or off, raising or dropping their powers, and changing their antenna patterns. These circumstances make for a jumble of regional stations ripe for the picking. Deep night is usually the best time for flat-out DX.

In 15-year stints at two locations in Maryland, I accumulated logs of over 600 and 400 stations, respectively. The most distant receptions, at 1800 to 2200 miles, were a few powerful stations in the Caribbean area and adjacent South America. I was aided, no doubt, by the largely water path between them and me. The farthest overland station was in Denver at about 1500 miles.

When I moved to Hawaii, I wasn't sure what to expect. The local Honolulu stations were givens. But what about the outer islands? And all-importantly the next stations, mainlanders, the

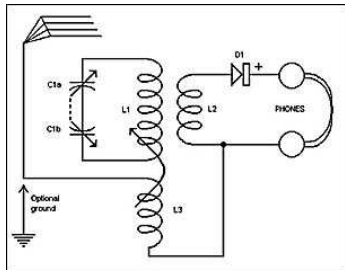

Fig. 6. Schematic of the '12,000 mile-er.'

crystal set alone, listen to it while you adjust the trimmers on the capacitor for best frequency coverage - particularly handy if you use a different size wire, different number of turns, different capacitor or different diameter core. Don't leave out the smaller coil of #22, or whatever you use; I tried this trap without the small coil, and it literally wiped out the whole BC band, no matter what frequency it was tuned to - on the other hand, if this is built to be resonant at the shortwave broadcast freqs, it cuts out a larger portion of the offending band.

More fun; put it in the ground path instead, and it works about the same. Put it before or after the antenna tuner (if you use one) - works about the same. Use it as a crystal set along with the other set, and you can listen to two stations at the same time - no, you can't listen to the same station with both sets if they are in series - the one rig cuts out the other. You can even use a trap to provide power to a small transistor amplifier stage if the trapped signal is large enough.

On the air testing with a dc millivoltmeter across the 47k resistor in my detector circuit (see my testing page) shows a signal reduction on "trapped" stations of about 6 to 14 dB with the trap. I suppose if you have a real monster in your neighborhood, you can put two traps on it for a double stomp; I couldn't see much advantage to the second trap when I tried this. I have not found the need to use a trap bypass switch when the trap isn't in use; I just shove the tuning cap to the other end of the band, and don't notice a reduction in set sensitivity elsewhere. I also notice that on really strong locals, the difference in signal level of 6 dB or so isn't very noticeable, and tuning the trap "by ear" is a bit difficult. When I tune off the offending station a bit, however, I can see the

effect of the trap more readily. I made mine as an outboard unit, but you can just as easily incorporate into your main set, just don't make the coils of the two circuits in line (on the same long axis) with each other or you will mutually couple them, which makes for confusing tuning.

One of the unexpected benefits of a trap, as I found out, is that it can enhance the operation of an otherwise sensitive but not so selective crystal set. Using a trap with slightly modified Radio Shack crystal set, I heard a brand new station coming in from several hundred miles away that was ordinarily masked by a stronger station.

Trapping with the pros: Probably the most effective trap is an inductively coupled one. Here's how to make and use it: Make a coil of the same dimensions as your set's main tuning coil, and parallel it with a variable capacitor, also like the one your set uses. Now, place the new trap coil in line (on the same axis) with the main tuning coil, and, with the set tuned to an offending station, tune the trap capacitor to null the station. You can vary the depth of the null by moving the two coils apart. If your set has a separate antenna tuning circuit, the trap coil should be on the side of the set tuning coil away from the antenna coil. I have one of these and have gotten over 30 dB of fairly sharp signal rejection with it. Be advised; when using an inductively coupled trap, expect some interaction with the tuning coil. Using an inductive trap can give some interesting results you don't get from one placed in the antenna line.

More trap fun: If you have a set using in-line antenna and main tuning coils, inductively coupled to each other, here is

These phones are low impedance and must be matched to the high-impedance tank (L2-C2) and detector diode by an audio transformer having, typically, 50- to 600-ohm and 50- or 100-kilohm windings (Figure 4). The quality of the transformer is very important, so that its insertion loss is small. UTC input transformers have a good reputation for low loss. The final touch is a comfortable set of headphone cushions for good acoustical coupling to the ears and exclusion of outside noise.

DX Experiences

Under favorable conditions, medium wave or broadcast band

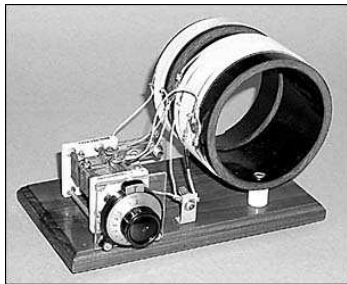

Fig. 5. A '12,000-mile' short-wave receiver.

DX crystal sets can receive hundreds of stations--some of them thousands of miles distant. In fact, DX crystal set performance is comparable to any other radio (powered or not) short of a full-blown communications receiver with its own outside

capability to put up one of these 'mega' antennas. So it behooves us to heed principles 1 and 2.

The front-end (antenna tuner) design shown here is one of several that can be used. This particular design tunes a wide variety of antenna-ground systems. Other DX crystal sets use a simple series tuning circuit effectively--especially on long antennas.

The diode detector provokes more mystery, controversy and debate than any other component. Some folks favor low-resistance germanium diodes like the 1N34A or rock stands with galenas. Others swear by high-tech Schottky diodes. The emerging truth is, there is no universally perfect diode.

The 'best' diode depends specifically upon the set it is used in. Per the second principle, the diode needs to match the tank circuit feeding it and the transformer and phones that it feeds. With some care, a high-Q tank with litz wire coil and a modern, military-grade variable capacitor can attain a resistance of from several hundred kilohms up to a megohm. Only Schottky diodes and a few modern germanium diodes have resistances this high. The old catswhisker-rock stand detectors have far lower resistances.

The most practical approach to selecting the right diode is to apply an A-B listening test to a number of them. Two diodes are mounted in a test stand arranged to quickly switch between them. Using a fairly weak station, one can test a pile of diodes, pair-wise, keeping the winner after each test, until the ultimate one is found. But it's most important to realize that this diode is 'best' for the particular set it was tested in. It may be a quite poor performer in a different set.

Surplus, sound-powered (more properly, balanced-armature) phones have become the industry standard for DX crystal sets. Baldwin Type C's were an early example. Now, post-WWII surplus units made by RCA and US Instruments Corp. (USI) are preferred.

something else to do with your inductively coupled trap. When trying to dig out a weak station, get as close to it as you can, then tune the trap for a null. Now, take the trap coil and place it between the antenna and main tuning coils. With some careful tuning, you can often isolate the weak station. The trap is giving you an additional stage of filtering and selectivity, and you are now using "triple" tuning. In this configuration, the trap is now functioning as a transfer circuit. You will notice that best performance is with the coils separated from each other by a coil diameter or so.

Larry Pizzella also reports good results with in-line traps using largish coils, with the tuned circuit portion of the trap inductively coupled to a separate coil connected to the antenna line which can be moved away from the main trap coil to provide variable coupling. If you look at his big radio, you can see a couple of his outboard traps as well as his inductively coupled trap (the large blue coil on the far right).

I would like to report that trapping my two strong locals opened up the top of the band for me; it didn't completely, but I can now get stations as close as about 20 kHz.

I have been able to successfully trap the HF ghosts somewhat that bedevil me early in the evening, but feel the need to work on this some more. Multiple hf intruders are really tough, but the hf trap I made doesn't use a coupling coil, and is rather broad, so gets a largish portion of the lowest shortwave broadcast band, and suppresses a couple of stations sometimes.

We have, from left to right: antenna-ground system, front-end (antenna) tuner, secondary (detector) tuner, diode detector, audio matching and finally, phones. Maximum transfer of available signal power from one stage to the next happens when the impedances of these stages are matched to each other--from antenna to phones--and indeed, from phones to one's ears.

Components

A good outside antenna-ground system is essential for DXing.



Fig. 4. RCA balanced-armature phones, with matching transformer.

Loop antennas do not have enough pickup to be effective.

An inverted L longwire 20 to 30 feet high and 50 feet long is a good start. The one truth to antenna design is, "higher is better." Any effort expended to raise the antenna, even a few feet, will be amply rewarded. In the

most recent crystal set DX contest a

third design principle emerged: A huge antenna can overcome shortcomings in the first two principles.

The winner suspended 140 feet of litz wire near vertically using helium-filled balloons. Another high-scorer just happened to have a 140-foot tall base-insulated tower and four 1000-foot Beverage antennas to complement his junk box set. Most of us have neither the real estate nor the rigging

Design Principles

Two fundamental principles underlie DX crystal set design and construction: use of low-loss components and proper impedance matching between stages.

Avoid the temptation to construct the set with vintage components. The result may be a handsome set that is only a fair performer. I have such sets, and they sit up on the shelf and look nice. However, for ultimate performance, one should rely on top quality (usually modern) components and materials.

This is especially important for tuning capacitors, coil wire and forms, and detector diodes. Layout and construction, particularly in the RF-carrying sections (antenna through detector), should follow good HF practices: short direct leads, careful insulation of components, and avoidance of switches, taps and other trappings in the 'hot', RF-carrying sections.

The crystal set, like any other radio, consists of a series of stages—each with a function, each coupled to the next. The stages of a simplified crystal receiver are diagrammed in

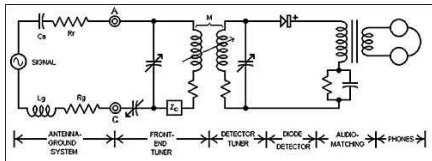

Fig. 3. The stages of a typical DX crystal set (see text).

Figure 3. The resistances shown are used for detailed circuit analysis that will not be discussed here.

BANDSPREADING TECHNIQUES

(20 June 99)

Owen Poole

<http://bellsouthpwp2.net/w/u/wuggy/spread.htm>

Bandspread in a crystal set? You must be nuts! Well, maybe so, but let's give it a shot anyway. Bandspreading is nothing more than making it possible for you to tune your set more slowly. Why bother? Well, if you are in a crowded band, such as in a metropolitan area with lots of strong stations, you have probably already gone for more sophisticated crystal radio designs to allow you to separate the signals. Even in my location, with two peanut whistles only 50 kHz apart, sometimes I still have to tune very carefully when my rig is set up to be selective so that I can get the station I want, and not hear the other. In the HF (shortwave) region, with stations fading out and then roaring back with regularity, being able to tune slowly allows me to catch stations that are just out of the mud, but are more often buried by the stronger stations that usually dominate, and which catch my attention easily. With HF ham rigs, the ability to tune slowly is an absolute necessity; otherwise you sweep right past stations that are only in your selectivity skirt for a few hundred Hz. Most crystal sets use a tuning capacitor that has only a 180 degree rotation in going from around 10 to 360 pF or so - on the BC band, this gets you through the 1.2 MHz-wide band rather quickly - on HF, you cover several MHz, and a quick sweep through the frequencies can cause you to miss stations if you are only expecting what you normally hear.

There are two basic types of bandspreading: Mechanical and Electrical

Mechanical: The simplest way to slow your rate of tuning down, or at least let you tune more sharply, is to use a larger tuning knob; your ability to control your tuning rate varies directly with the diameter of the knob, assuming you grab it on the outside edge. Another method that used to be popular was to have a small diameter shaft turning a larger diameter one connected to it by a dial cord; the cord was usually kept tight by a small spring. A third way, still much in use, is to have a planetary dial drive which makes several rotations to drive the capacitor through one half a rotation. Dial cord drives are tricky, and planetary drives can cost more than the rest of the set, so I usually go for the largest knob I can find. Another thing to watch out for with mechanical bandspread drives, should you try one, is backlash or slop - you reverse your direction, and lose a couple of degrees of turn before the capacitor starts to move. For inductive tuning, usually consisting of moving a ferrite core in and out of the coil, the once readily available AM tuning coils used to come with a metal cap through which a screw protruded that allowed you to vary inductance very slowly using a small knob to twist the core in and out. Compression capacitors also use a screw to let you make several turns from stop to stop, but aren't ordinarily used for main tuning, and are usually for screwdriver use only. If you do stick a knob on a compression cap with some epoxy, a soda bottle cap should work, and will allow you about 3 or more revolutions of rotation stop to stop.

Electrical: Nothing magic about this either. Here you use two or more capacitors to change the amount of capacitance a turn of the knob gives you. Shown below are some of the more common ways to electrically bandspread your tank circuit:

So, what makes a crystal radio a "DX" set? Well, this one is double-tuned (L1-C1 and L2-C2) for selectivity to tune weak DX stations in the RF jungle we now live in. Some DX sets resort to triple tuning for even more selectivity -- depends on how many hands you have to do the tuning. The wavetraps (L3-C3 and L4-C4) can be tuned to reject strong unwanted stations in the manner of the notch filter on a communications receiver.

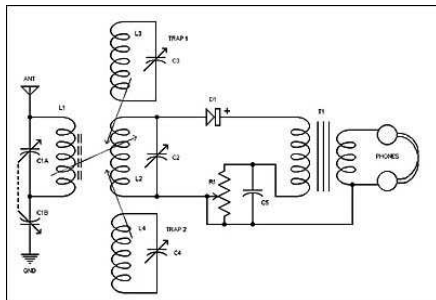

Fig. 2. Schematic of the 'Lyonodyne-17.'

Coils L2 through L4 are basket-wound litz wire for low loss and high Q. Variable capacitors C1 through C4 are highest-quality, silver-plated, ceramic-insulated units--as perhaps only the military could specify. All these components are isolated from the mounting board by ceramic standoff insulators. Overkill maybe, but why take chances?

particularly interested in crystal sets since 1959, when I first discovered you could actually DX with them.

The Internet has aided crystal set DX activity by making exchange of ideas between like-minded enthusiasts much, much easier. This article only touches the surface from a personal perspective. The reader is encouraged to pursue the online resources, described below, covering all aspects and providing further examples of this fascinating hobby.

In this article I'll cover general design considerations for building DX crystal sets, but will leave the actual construction specifications up to you.

Equipment

Figures 1 and 2 show an example of a DX crystal set. I call it the "Lyonodyne-17." The design evolved from an earlier version described in the November, 1978 OTB. As you can see, this is not your grandfather's crystal set.

Antenna (right) and detector (left) tuners are mounted on the middle board. Wave traps are located fore and aft on separate boards, making it possible to adjust the coupling by moving the boards. The antenna coil (L1) is wound on a short ferrite rod. The matching transformer unit for my RCA "Big Cans" sound powered phones is at front, left.

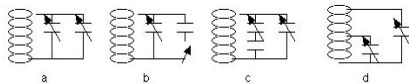

Figure a. is one of the favorites. If one capacitor is significantly larger than the other, it is called the band set capacitor, and the smaller one is the bandspread capacitor. Capacitor size ratios of from 2:1 up to 10:1 should be used. Keep in mind with all of these that minimum circuit capacitance is the sum of the minimum of both capacitors. Since the polyfilm caps I usually use, because they are cheap, only run to about 200 pF, I sometimes just put 2 in parallel to get full AM band coverage (and 360 degrees of rotation at the same time). Incidentally, since these capacitors are really two sections, a 150 pF and 50 pF, you can get full band coverage with a 200 pF capacitor, with both sections tied together, and only the 150 pF section on the other; use the 150 pF section for the top part of the band and it will slow your tuning rate down a bit.

Figure b. is sort of a poor man's bandspread, switching in one or more fixed capacitors to increase capacitance in increments, then adjusting the variable as needed. I used this with my peanut special to get to the bottom of band. The fixed capacitor should be no larger than the range of the variable to prevent skipping over frequencies.

Figure c. has a fixed capacitor in series with one of the variables. This reduces the tuning range of the series variable from about the minimum of the variable to the value of the

larger capacitor in the series branch. Good to use if you don't have any small value variables.

Figure d. taps one variable down on the coil, reducing its effect on tuning range. In this case, assuming it is the same value as the band set capacitor for example, its effect capacitance-wise over its full range is approximately equal to the percent of the coil it parallels. If you use a switch to select different coil taps, you can thus vary your bandwidth.

A note on using fixed capacitors: I have found that some are better than others, and a lossy one can reduce set sensitivity when the fixed cap is switched in. I have seen this with the readily available ceramic disc capacitors. This may not happen to you, but just be aware of the possibility. You might want to try different types here. Try to use good quality switches as well, and make good solder connections....

Finally, to use the K.I.S.S. principle, use a capacitor with a range no bigger than you need. That is, use only enough range to cover that part of the spectrum in which you are interested. Using a single 365 pF capacitor on the HF bands, one turn of the dial will sweep through several MHz, and no matter how selective your crystal set, you will be sweeping through a lot of dead frequencies and then sweat tuning in and then separating the stations you want to hear.

You can pretty much do with inductors (coils), what you can do with capacitors, and some of the old designs used a lot of variable inductances. Putting inductors in parallel has the

DESIGNING A DX CRYSTAL SET

by Mike Tuggle

46-469 Kuneke St.

Kaneohe, HI 96744-3536

E-Mail: tuggle@apacs.com

<http://www.antiquewireless.org/otb/dxxtal.htm>

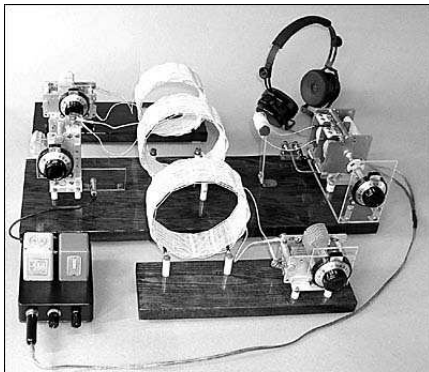

Fig. 1. The 'Lyonodyne-17,' an example of a well-designed DX crystal set.

Long distance reception with crystal radios is once again becoming a serious pursuit among hams and other radio hobbyists. They are discovering that the DX capabilities of these receivers have been greatly underrated. I've been

- T1 Stanley audio transformer Part Number 227-E-1-3-98
Pri 100 ohm Sec. 100M (100k) ohm
(Fair Radio Sales number T3/AM-20)
- T2 Bogen T725 4 watt P/A transformer (Check the bottom
of this page)
- R1 250k ohm variable resistor #
- R2 2 to 3 Meg ohm variable resistor
- SW1 12 position single pole rotary switch (Radio Shack)
- SW2 12 position single pole rotary switch (Radio Shack)
- SW3 6 position single pole rotary switch (Radio Shack)
- SW4 DPST Toggle switch
- SW5 SPST Toggle switch
- C1 .1 uf capacitor
- C2 4.7 uf capacitor non polar (Radio Shack)
- C3 2.2 uf capacitor non polar (Radio Shack)
- C4 1.0 uf capacitor non polar (Radio Shack)
- C5 .5 uf capacitor non polar (Radio Shack)
- C6 .05 uf capacitor non polar - (Radio Shack)
- C7 .1 uF Capacitor #

Notes: # Not used in UltriMatch, only in UltriMatch 2

same effect as putting capacitors in series, and vice versa for series inductors. My uncle Elmer (I must have had one sometime) told me, however, that circuit Q was highest when you used as much inductance as your frequency range allowed, and to let the capacitor do all the "heavy lifting". Still, some of those old variable inductors look pretty elegant, and I am sure they work pretty well, even if they are a bit more complex to build.

switching the absolute phasing, don't worry about it. Many cannot and it's one less thing for you to concern yourself. Position 1 on SW1 permits use of an efficient 4, 8, or 16[^] speaker on very loud signals, or use of headsets with very low impedance ratings similar to those speakers.

Output Using Input2/Output Combo

The 'High' side terminal of input 2 may be used as the 'return' for the headset for the xtal detector function if it is desired to select a winding ratio 'inside' the normal selections. Connect the headset to the 'high' side output terminal (from SW3) and it's other lead to the 'high' side of input 2. SW1 is then used to select a tap for the 'low' side of the headset connection, SW2 selects the 'high' side as before. This 'inside' option excludes selection/use of the position '1' 8[^] speaker tap. Some headsets will match up better using this option.

Absolute phasing may then be reversed/corrected by reversing the switching order of SW1 and SW2, thus reversing the 'high' and 'low' sides of the headphone connections without need to disconnect and swap them, once the best ratio selection is found by ear. Correct "Absolute phase" refers to the condition where a pressure 'push' into the studio mic gives a pressure 'push' from the speaker or headphone. Absolute phase reversal results in an unnatural result of a 'push' giving a 'pull'. Some listeners find clearer & more lifelike voice sounds when absolute phasing is correct.

Steve Bringhurst

Parts List
(UltiMatch and UltiMatch 2)

to the headphone being used. The position giving the loudest & clearest sound is usually the best setting. SW3 is used to select bass response balance for the headset and input device in use, the 1st position is 'direct'. This adjustment will have a more subtle effect than a regular tone control.

Input 2

Input 2 is used for powered devices like tube & transistor detectors & amplifier ckts with SW4 in the 'low' position. SW1 is used to select the proper input match for the powered device. Always start from the highest setting first when using this function, too low a setting may damage the powered device. Using SW2 selects the best match for the headset as before, or position 1 can drive a loudspeaker directly. The loudest & clearest sound is usually obtained when SW1 & SW2 are optimum.

Output

Any set of headphones or single earpiece, such as a telephone earpiece, may be connected to the 'output' terminals. It is usually preferable to have 2 earpieces connected in series, rather than parallel, & properly phased so that the sounds seem to occur 'inside' ones head between the ears and not 'at' either ear. Switching the connections to one earpiece will correct phasing. Some listeners can hear a definite difference in intelligibility when the headphone connections to the transformer device are switched around (which reverses 'absolute phase'), the clearer sound has correct 'absolute phase' and is of course preferable. It is generally a one-time adjustment, but not always for every station, program, ect . This can change if the station or studio is careless about engineering practices and allows reversed absolute-phase signals to occur. If you cannot hear a difference when

SELECTIVITY ENHANCEMENT CIRCUITS

<http://makearadio.com/misc-stuff/dxnotes.php>

Dave Schmarler's Hints and tips...

I would like to talk about selectivity enhancement circuits (SEC). Some refer to these as the "Hobbydyne". Jim Frederick in Florida came up with the Hobbydyne circuit. The earliest publication of a SEC I have seen was in Australia in the early thirties. [Jim Frederick's Site](#) [Here is the Australian page](#). So you see that what appears to be new, sometimes isn't. But Jim's Hobbydyne was new. Also his first (to my knowledge) recent use of the SEC is credited to Jim.

The SEC and Hobbydyne do the same thing. They allow unloading of the tank circuit, thus increasing the loaded Q, which means better selectivity. It also provides a better match between the tank and diode (and audio circuits further down the line). This is better than the old fashioned way of matching and unloading - tapping the coil. The basic SEC consists of a small value variable capacitor (usually around 20-30 pf), and a small RF choke. I found that a 27 millihenry value is good. Some have used a reverse biased diode in place of the choke. The choke or diode is to complete a DC path so the detector can work properly.

Jim discovered this feature while experimenting with his crystal sets in 2003. He sent me an ie-mail and invited me to test this circuit. I tested it on my, at that time current dx receiver, my [#35 radio](#). It didn't take me very long to see the value in this discovery. I knew that this was going to be a

UltiMatch and UltiMatch 2(new)

by Steve Bringhurst

This is a "All in one box" unit

This incorporates the Select to Match ("S-T-M") and the Universal Match-Box ("Uni-Match")

all in one unit. Get the most out of your components!!

Original UltiMatchCircuit

Original circuit has been left here so those who have already built the circuit can see easily the differences in the two circuits.

This will help if you would like to "convert" to the new circuit.

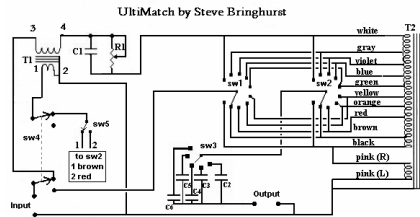

UltiMatch 2(new)

additional tracking capacitor. That is recommended if you can spare the capacitor. Another hookup would be for you to use two small capacitors in a quasi differential capacitor. You can manually increase one capacitor while decreasing the value of the other one. This will give you that capacitive divider effect.

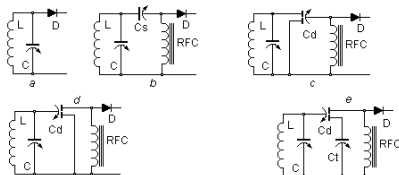

L= Main Coil, C= Main Tuning Cap, CS Selectivity Variable (20 pF), D= 1N34A etc.
Cd= Differential Cap (20 pF) Ct= Tracking Cap (10 pF), RFC= 27 mH Choke

Crystal Radio Selectivity Enhancement Circuits (c) 2006, D. Schmacher

T2 Bogen T725 4 watt P/A transformer (Check the bottom of this page)

sw1 12 position single pole rotary switch (Radio Shack)

sw2 12 position single pole rotary switch (Radio Shack)

**Universal Match-Box
"Uni-Match"
by Steve Bringham**

Another idea from Steve Bringham is the "Uni-Match" or Universal Match-Box. This simple box will match just about any type headphones to just about any type radio. Not designed just for crystal radios, but for just about any type radio. "Say you want to use your S/Ps or Brush-Clevite piezo's, or your Telephonics TDH-39s or?? on a tube or xistor regenny, MK-484 TRF, the output of your regular radio, ect, ect. You could do any and all with this." Steve Bringham

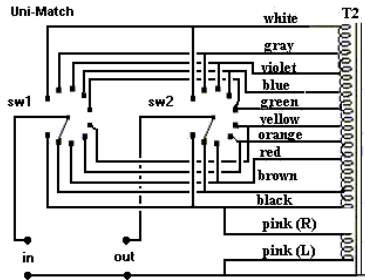

Starting at the first position on the switches and going clockwise the impedance should be approximately 40k, 20K, 10k, 5k, 2.5k, 1.2k, 600, 300, 150,75, 8 (all in ohms)

CONTRA WOUND COILS

<http://makearadio.com/misc-stuff/dxnotes.php>
Dave Schmardeer's Hints and tips...

Hi Friends. Welcome to my contra coil page. The coils that I am showing on this page are used as the main tank coils for crystal radios (and tube radios too). I believe that this improved type of tank coil will be one that you will want to incorporate in your next crystal set. I owe the ideas on this page to Ben Tongue. A while ago he published this very interesting article on his [web site](#). The [article](#) describes a radio he built that has a constant receiving bandwidth across the MW broadcast band. Reading this article is very worthwhile.

My goal isn't to have constant bandwidth, but improved performance where it is really needed, at the top end of the band. There are several difficulties in tuning the high end of the band and I believe the contra coil will improve your dx reception.

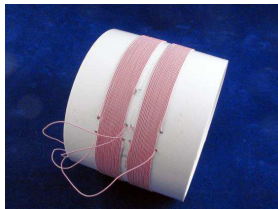

The contra coil in its simplest form is two equal coils wound on the same coil form, but in opposite directions. The coils are connected in

series to tune the low end of the band and in parallel for the high end. How the coil is wound and connected is where the secret lies. With the windings wound as they are, the losses are low and the Q is high. The variable capacitor also operates in the sweet spot, further cutting losses. On the high end of the band, the litz strands are doubled with the parallel connection. That's got to be good!

Ben's coils have extra taps for the diode connection. The tap used is dependant on the part of the band that is tuned, along with connecting the coils in series or parallel. He splits the band into 4 segments. For now, I'm leaving off the taps and going with a hobbydne type circuit that will allow for variable tank loading and matching.

The first coil shown is my test prototype cylinder coil. I felt I should build one cylinder type to get the feel of how this coil will operate. The coil form is a styrene sewer pipe coupler. I bought it at [Home Depot](#). The outside diameter is 4-1/2 inches (11,5 cm). There are 22 turns of [165/46 litz wire](#) on each winding. Each coil calculates out to 27 feet (8,25 m), including 6 inch (15 cm) wire leads. The start (s) windings are in the center, and the finish (f) windings are towards the form edges. When winding the coil, start at the center. Wind the first coil. Then when winding the second coil, beginning again at the center. The two start windings will wind in the same direction around the form. That makes the coil wound reverse, or contra wound around the form.

To connect the coils in series connect the start of one coil to the finish of the other coil. The other leads are connected to the

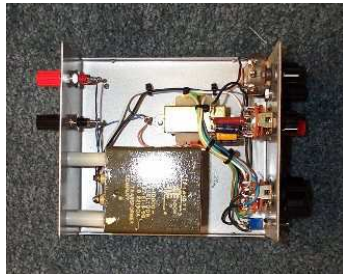

put in for 10k Hi "Z" headphones (Radio Shack)

Notes:

- 1) The range of C1 can be from .05uf to .22uf. It is not that critical.
- 2) Only ten of the twelve positions are used on SW1
- 4) #1 lead on T1 goes to SW3. It is split and one lead goes to brown on SW1 and the other goes to red on SW1. This allows you to shift the ratio range a full step for better use of the Stromberg Carlson elements.
- 5) Experimentation is the key to getting the right values on this unit.
What is right for you and your set up is what counts.
- 6) See photo below for proper phase ID of the two "pink" wires on the Bogen 725 transformer.



My version of Steve's S-T-M Stanley/Bogen

rest of the circuit. For parallel operation, the two start wires are connected together as the two finish wire are connected together. The connections to the rest of the radio are from these points.

When the coils are in series, the inductances add (plus the mutual coupling). This is because the coils are in phase. It is just that the wiring connections jump to different positions on the forms. When the coils are in parallel, they are also still in phase, but at 1/4 the original inductance value.

The inductance is approximately 240 μ h in series and 60 μ h in parallel.

It is likely that you will want to use some kind of switch to go from series to parallel. Try to find a low loss switch, such as a ceramic rotary switch, or use thumb nuts, and brass links mounted on low loss materials. The circuit is shown below. It is important that the coil and switch be wired exactly as shown. If your radio doesn't work, check the wiring first. I included the physical wiring pictoral below. This is from my #64 contra radio. The picture of the switch is the top view, while the pictoral is how it is wired from the bottom.

Design Your Own Contra Coil

Now how do you design your own contra coil? Here is the place to start. You may want to skip this part for now and look below at the pre-designed coils. If your tuning capacitor

matches one of the situations below, you don't need this section.

You will need a few things before you start. First, bookmark this page on crystalradio.net. This link sends you to Dan Petersen's *Professor Coyle* calculator. This takes nearly all the math out of designing your own coil. You want to select the [cylinder coil calculator](#) as this one has the resonance calculator.

If you build a coil, you should have an L/C meter. I use the one produced by [AADE](#). It is important to be able to balance the inductances of the two coils. If you don't have one, you can just shoot for the best by using the designs that I have made.

If you want to test the actual tuning ranges, you will need an accurate signal generator, a capacitance meter and a scope or other rf level indicator. If you are building one coil, you can just put it in your crystal set and check out the tuning range by listening for the stations.

It is best now to go over some of the basic design criteria, map out what we have and discover a few truths and speculate on some assumptions. So here we go:

The contra coil has a 4:1 inductance ratio between series and parallel. 240:60 μ h for example.

S-T-M Stanley/Bogen "Select to Match" Impedance Matching Circuit Circuit Design by Steve Bringham "baldy3823"

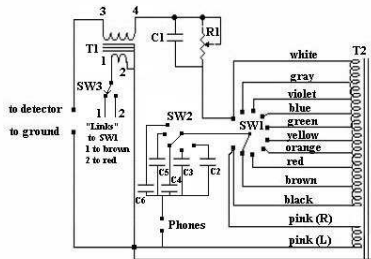

- T1 Stanley audio transformer Part Number 227-E-1-3-98
Pri 100 ohm Sec. 100M (100k) ohm
(Fair Radio Sales number T3/AM-20)
- T2 Bogen T725 4 watt P/A transformer (Check the bottom of this page)
- R1 250k ohm variable resistor
- SW1 12 position single pole rotary switch (Radio Shack)
- SW2 6 position single pole rotary switch (Radio Shack)
- SW3 SPDT toggle switch (Radio Shack)
- C1 .1 uf capacitor (Radio Shack)
- C2 4.7 uf capacitor non polar (Radio Shack)
- C3 2.2 uf capacitor non polar (Radio Shack)
- C4 1.0 uf capacitor non polar (Radio Shack)
- C5 .5 uf capacitor non polar (Radio Shack)
- C6 .05 uf capacitor non polar - not shown in circuit can be

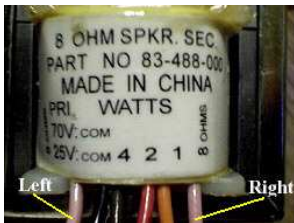

My version of Steve's S-T-M Calrad/Bogen

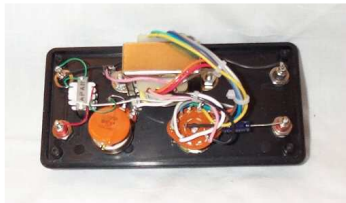

The S-T-M is excellent for comparison of headphones. It works very well for one or two sets of phones as well. It will run a range of headphones, from magnetic to sound powered.

The low end of the tuning range should be 530 khz. Better to design to 520 khz. The larger the value of your variable capacitor, the lower this is likely to be.

The high end of the series coil connection should reach above 1000 khz. This may not be possible. Just so the next condition is met, all is ok.

The low end of the parallel tuning should overlap the series high end by 30-50 khz.

The tuning ranges should span the dial over a total of 240-300 degrees.

A variable capacitor as low as 15-280 pF can be used but a higher value is recommended.

The variable capacitor shouldn't be over 500 pF.

Figure on about 25 pF capacitance added by the radio detector circuit and coil distributed capacitance.

An air trimmer capacitor of 75 pF is recommended. This helps with dial spread.

If you build the coil too large, you will lose dial spread but you will tune the whole band.

If you make the coil too small, you may not be able to get that 30-50 khz mid band overlap. (This assumes that you would have to increase the trimmer a lot more.)

The higher that the total maximum to the total minimum capacitance ratio is, the wider the tuning range will be. This means that the dial spread would decrease. Look at the pictures below in the *Other Adjustments* section

Being that the main tuning capacitor range and the fixed added values (diode circuit and coil distributed capacitance) is pre-determined, it comes down to juggling the coil value and the trimmer capacitor value to get the best spread with full tuning range.

- R1 250k ohm variable resistor
- SW1 12 position single pole rotary switch (Radio Shack)
- C1 .1 uf capacitor
- C2 Value of C2 depends on the set up of the headsets.
(all non polar)
 - 1) one 600 ohm impedance element = 1 uf
 - 2) two 600 ohm impedance. elements wired in parallel = 2.2uf
 - 3) two 600 ohm impedance elements wired in series = .5 uf
 - 4) 10k Hi "Z" headphones = .068uf to .05uf
 - 5) two low "Z" elements in series like Stromberg Carlsons can be run on 2.2 uf, but 4.7uf might be a better match up.

Notes:

- 1) 1 uF is a good fixed compromise value for C2 if several different impedance headsets will be frequently used.
- 2) The range of C1 can be from .05uf to .22uf. It is not that critical.
- 3) Only ten of the twelve positions are used on SW1
- 4) White lead on T1 goes to the rotary switch SW1 with yellow
- 5) Experimentation is the key to getting the right values on this unit.
What is right for you and your set up is what counts.
- 6) See photo below for proper phase ID of the two "pink" wires on the Bogen 725 transformer.

S-T-M

"Select to Match"

by Steve Bringhurst

The "Select to Match" was designed to allow a person to experiment with different headphones on the same crystal radio.

If you are using only one set of headphones only, you might want to build the dedicated circuit below which will save you space, time and money.

STM introduction

S-T-M Calrad/Bogen

"Select to Match" Impedance Matching Circuit
Circuit Design by Steve Bringhurst "baldy3823"

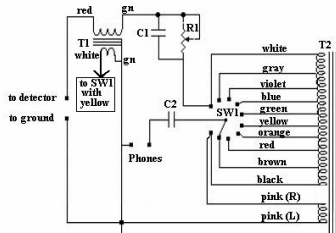

T1 Calrad 45-700 audio transformer (Ocean Electronic)

T2 Bogen T725 4 watt P/A transformer (Check the bottom of this page)

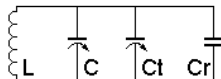

L= Coil Under Design - Series & Parallel
C= Main Tuning Capacitor Min & Max Value
Ct= Trimmer Capacitor 75 pf max
Cr= Radio Capacitances, 25 pffixed

Crystal Radio Contra Coil Design

Here is an example: To start, you have to measure and add the capacitances for when the tuning cap is at minimum and maximum. Add 25 pF for the extra radio capacitances. Also include a starting value of 10 pF for the trimmer setting. The values are reached by rocking the values back and forth until a suitable value for the coil is found.

Let us assume a 15-350 variable capacitor plus 35 pF for the extra capacitances described above. You can see them in the schematic shown above too. This means that the circuit capacitance ranges from 50 to 385 pF. These are starting values, and the minimum and maximum values are likely to be more like 80 to 415 pF as the trials go on. The starting value for the inductor is 240 and 60 μ h.

Starting with the low end, plug in a value of 240 μ H and 385 pF into Professor Coyle. That is a pretty close 524 khz. Lucky, h μ H? Ok, now use the 240 μ h coil and plug in the minimum total capacitance. That comes to 1453 khz. That is too wide of

a frequency spread. Instead of going further, we will change the maximum and minimum capacitor value and start over.

Now plug in a higher value of maximum capacitance and adjust the coil value to a 520-530 khz range. Let's try 415 pF. That drops it down to 504 khz with a 240 μ H coil. Let's reduce the value of the coil. 225 μ H brings the frequency in at 521 khz. Now let's try the minimum value of 80 pF with a 225 μ H coil. That sets it at 1186 khz.

Ok, it is time to try the high range. Since the low range is 225 μ H, the high coil will be about 56 μ H. The low end with 415 pF now tunes 1044 khz. We have more than enough overlap, but the parallel coil low end tuning range is a tad high.

So let's go back and turn up the trimmer 20 more pF. This will give us a capacitance range of 100 pF to 435 pF. 225 μ H with that capacitance tunes 1061 to 509 khz. The 56 μ H coil and 435 pF tunes to 1020 khz. That is a 41 khz overlap. This looks like a good value to go, but let's make one more tweak.

How about raising the inductance to 232 μ H. The tuning range is pretty good but the low to high band split is a little higher than I like. The capacitance at 100 to 435 pF is good. Remember that the trimmer will take care of the inaccuracies.

So 230 μ H and 435 pF tune to 501 khz and at 100 pF tunes to 1045 khz. The parallel coil is now 58 μ H. That tunes down to



Stanley Match built by Mike Tuggle

The StanleyMatch is nothing radically different from other phone matching units, just a way to get more flexibility from the Stanley/UTC TF-1A-10-YY input transformers still available at a bargain from Fair Radio. By some nifty switching, one can combine two single 100 k-to-100 ohm units to get five different input-output impedance pairs. The key component is the 4-pole, 5-position switch. These come in the form of 4-deck rotary switches, as 2-deck switches with two independent 5-position sections on each deck, as shown here (actually, the sections are 6-position with one position blocked out) -- or possibly as single deck switches with two independent sections on each side! On a 4-deck switch several positions will likely need to be blocked out. That's what those tabs at the collar are for.

The 2 x 3 x 5 in. mini-box is about as small as I would suggest going -- unless you are a micro-circuitry freak and/or don't mind the smell of insulation burning on your soldering iron. Even so, I had to pre-wire several of the components before installing them in the box. Details like exact pot and capacitor value and connector types are user's choice. I just happened to have 'standardized' on 1/4-in. phone plugs and 1/8-in. miniature output jack on my sets.

The low impedance (50 - 200 ohms) outputs make this unit especially suitable for low impedance sound powered phones. I suppose you could Bogenize the low impedance end to match higher impedance magnetic phones. I've been quite happy with SP's and haven't seriously tried other types. The test points (TP) mounted on the rear apron are for audio voltage output measurements if so desired.

1002 khz. That is a 43 khz overlap. The trimmer will let you adjust to 1041 to 998 or 5 channel overlap.

Now a couple of things: First, you won't get the coil that close, but if it is plus or minus 5 μ h, that is fine. The trimmer will iron out the glitches.

Notice that we didn't talk about the high end of the band in the parallel coil configuration. This isn't important as it will always fall above 1700 khz.

You will have good dial spread with these values. The actual dial spread will depend on the shape of the capacitor plates (straight line capacitance, or straight line frequency). You will have better dial spread than with regular wound coil.

If you are unsure, wind the coil on the large side. It can be taken apart and adjusted if you are real far off. It is better to have less dial spread than not being able to tune the band.

This works with a cylinder wound coil or spider coil.

So to recap, we found a **232/58 μ h coil** would be good with a **15-350 pF capacitor** with a **60 pF trimmer** (with the fixed 25 pF for the radio and coil capacitance).

Recently Jeff Welty whipped up this page for calculating spider contra coil. It is very complete, from entering the data to printing a coil form template.

So [here](#) is the calculator. I'm sure this will take the misery and doubt out of your coil building.

I wish you the best success with your coil. (and luck too) :

Dial Spread

There is a special feature that comes with the contra coils. That is, the tuning range on each band is somewhat wide. This means that a capacitor with a big capacitance ratio isn't really needed. But what happens is that the dial spread is not as good as it could be. Take a look at the two pictures. They are the same radio, kind of a before and after shot.

The top picture shows the tuning covers a much narrower part of the dial scale as the bottom picture. You have to look close at the numbers as the ranges are a little different. The left side is the low band (530 - 1000) and the right side is the high band (900 - 1700).

The difference is that I placed a small trimmer capacitor (about 75 pF maximum) across the main variable capacitor. Now the capacitance ratio of my variable is about 6:1 (90-550pF). Before the ratio was about 23:1 on this capacitor (20-475pF).

Stanley Match by Mike Tuggle

Stanley Match

by Mike Tuggle

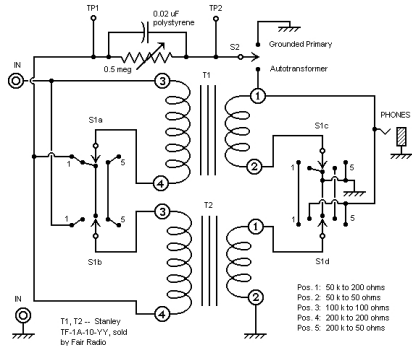

The StanleyMatch combines two of the bargain Fair Radio transformers with a 4-pole, 5-position switch to provide several high-to-low impedance matches especially suitable for low impedance sound powered phones.

StanleyMatch by Mike Tuggle

Strombergs are lower AC Impedance than most other sound powered headsets and can benefit greatly with this circuit. This will help them perform closer to the other "Big Can" decktalkers. Also works great if using the "mic" elements out of decktalkers. "Mic" elements are also lower impedance.

I did try a more aggressive type of band spreading using both a trimmer capacitor along with a padder type. But since I am stuck with a fixed 4:1 coil ratio, I had some trouble getting the dial spread to work correctly on both ranges. However with the way I did the dial spread, I get about a total of 2 turns of the knob in each range. A regular coil set, such as [my #63](#) is just under 3 turns of the knob to cover the entire band. Another contravantage.

Your actual situation will be different, depending on the actual components you use. But after you build your set with a contra coil, investigate using a trimmer to widen your dial spread.

UTC A27 Transformer

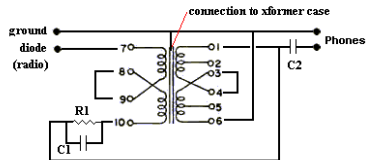

Circuit for a UTC A27 Transformer
 An excellent very low loss transformer
 (This circuit has been revised on 29 January 2004)

Dual Calrad 45-700

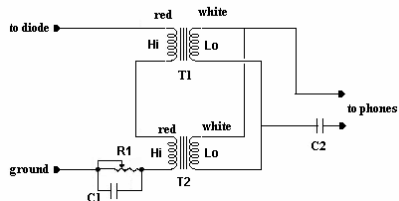

Dual Calrad 45-700 xformers
 Excellent when using Strombergs Carlson and Dynalec Decktalkers.

C2 .47uf capacitor

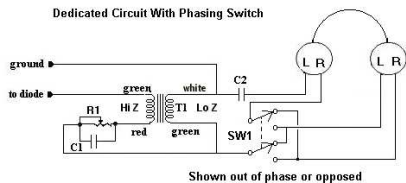
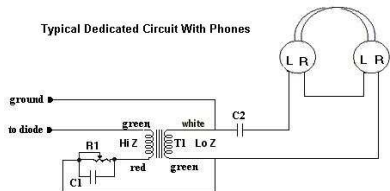

BASKET / SPIDERWEB COIL DESIGN

PA2MRX

http://www.pa2mrx.nl/UK/coil%20homebrewing_uk.htm

The tuning circuits of my xtal sets are made out of old fashioned type of coils as seen in old magazines and photo's, these can be Honeycomb, Basket weave, Spiderweb and other forms of coils. In German these are: Honigwablen, Korbspule, Spinnwebenspule. Basket weave coils are also mentioned in books as "Lorenz" coils, and can be made in different shapes and sizes, as the Honeycomb and Spiderweb coils.

These coils were made because of their low own capacitance, this gives your coil a higher Q because the windings are further apart from eachother, there is more air between the layers.

You can make your coils using enameled copper wire, or silk or cotton insulated wire. Better if you make coils for the middlewave band using Litze wire, this wire is made out of many insulated smaller wires, from 3 up to 1500 or more small wires. But the more wires, the more expensive the wire.

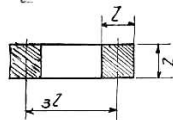

Fig. 19

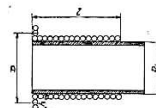

Fig. 20

A honeycomb coil is not more than a one layer cylinder coil. Many variations are made of this type of coil. After many tests and research they came to the conclusion that the selfinduction is going through a maximum when the cross section has a rectangular form (Thickness is same as width) like in fig.19 is the same, and when the average diameter is the same is 3x the thickness of the winding

Calculation of Spiderweb/basketweave/cylinder coils can be done with the "prof. coyle" programme, but I didn't find a formule to calculate honeycomb coils, these calculations were so complex they only published the data to create these honeycomb coils. I have the data below as found in old books:

Used capacitor in table 1 is 1000cm (+/-1100pF) wire size 0,5mm. The coil form has a diameter of 5cm, thickness is 4cm.

# Windings	Wire Length	Wavelength
25	4m	180 - 430 meter
35	6m	200 - 550 meter
50	9m	250 - 700 meter
75	14m	400 - 1000 meter
100	20m	500 - 1300 meter
150	30m	700 - 2000 meter
200	42m	1000 - 2700 meter
250	50m	1300 - 3600 meter
300	63m	1600 - 4200 meter

Source : Bastelbuch fur radioamateure, 1925

Coilform in table 2 is 5cm in diameter and a width of 2,5cm. Own wavelength is the wavelength of the coil with its own capacitance.

Winding I #	Self mH	Wire		WL m	Range with C 50-1000pF m
		WL m	mm		
25	0,05	50	0,56	4 meter	90 - 400

DEDICATED IMPEDENCE MATCHING CIRCUITS

Darryl Boyd

<http://www.crystalradio.net/soundpowered/matching/index.shtml#Dedicated>

This "fixed" setup is designed for standard 600 ohm impedance elements wired in series.

It is a standard matching transformer circuit.

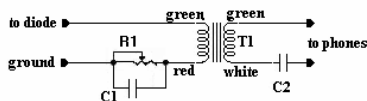

The following is another dedicated circuit for two 600 ohm series wired elements.

The transformer is set up more as an autoformer.

I think it performs a little better than the above circuit.

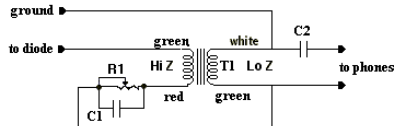

Try both circuits. They use the same parts!

T1 Calrad 45-700 audio transformer (Ocean Electronic)

R1 250k ohm pot (a mini pot would work great!)

C1 .1uf capacitor

35	0,09	90	0,56	6 meter	120 - 550
50	0,16	110	0,56	9 meter	175 - 750
75	0,3	150	0,56	14 meter	250 - 1000
100	0,6	200	0,56	20 meter	300 - 1500
150	1,5	280	0,56	30 meter	500 - 2000
200	2,5	350	0,4	40 meter	650 - 3000
250	4	400	0,4	50 meter	800 - 3500
300	6	500	0,4	60 meter	1000 - 4500
400	10	600	0,4	80 meter	1250 - 6000
500	15	700	0,3	120 meter	1500 - 7000
1000	70	1500	0,2	225 meter	3000 - 15000

Source: Der radioempfangsapparat, 1924

Coils as in the upper tables are made on a coilform as seen on description and photo's below, but you can alter these by varying number of pegs used.



The Honeycomb coil

Coil form with its measurements are in the following drawings. You can use your own measurements and the number of pegs. But the above values are for these coils here.

You can make your form out of wood, but I made it out of alluminium on a lathe, the pegs are made out of knitting pins, bought these at the weekly market here, if you buy these with 2

pointed sides you can make two pegs of $\frac{1}{8}$ "m, so you need to buy half of the knitting pins you need for the coil form.



Abb. 54. Der Spulenkörper mit den eingetragten Druckstiften.



Abb. 58. Spulenkörper zum Wickeln von Honigwabenwinden.

A Honeycomb coil is getting larger in diameter the more layers are wound

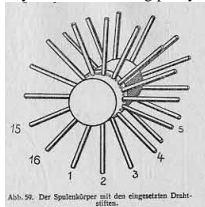
on it, but the width stays the same.

You can use your own style the make your coil, over2/under2, over2/under3, over3/under2. Do it as you like and look at the results.

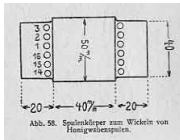

Abb. 56. Wicklungsdiagramm für Honigwabenwinden.

2. Over 2/under 2 fertig montierte Honigwabenwinden.

Winding method seen at the left: Over1/under 4.

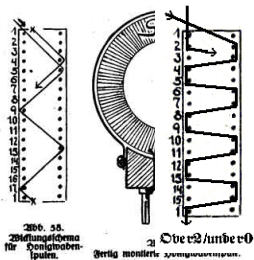
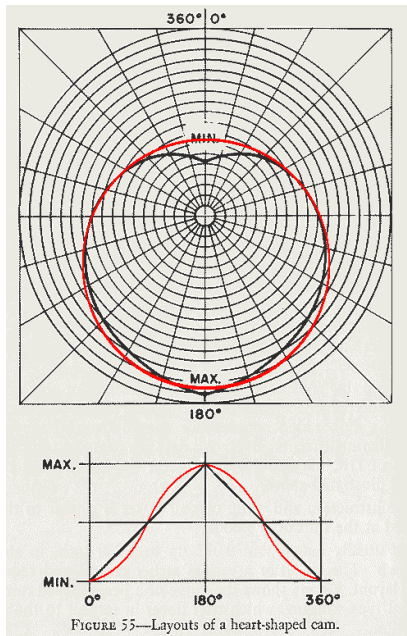

FIGURE 55—Layouts of a heart-shaped cam.

I also made a aircoil out of 6mm copper brake piping, 11cm in diameter, 8 windings, space between winding is 6mm.

These type of coils were used very often in old radio equipment.

Self resonance at 17.690Mhz, -3db point at 17.980 and 17.350, makes a bandwidth of 630Khz.

Q of this coil at 17.690Mhz is $17.690/0.63=28$

How do I get I veeery high Q at shortwave...I think never, even a aircoil I made with a diameter of 25cm had a low Q.

21-7-2008

I also made myself a coil winder according to the Gingery Coil Winder manual. With this type of winder you can make yourself some nice small radio coils for your project.

The coil winder in the above links are in principle the same as the Gingery winder, only the cam has been changed into a heart shaped one. This type of cam has the advantage that the wire does go around the circumference of the coilform in a triangle shaped fashion, instead of a sinus with the round shaped fashion. The heart shaped cam gives the coil a much higher stability when winding the coil. Below a scan from WM. Querfurth's book of the heart shaped cam with the round excentric cam in red to compare the two cams.

If you use only one side of the coil form, you can wind your spiderweb coil on this coilform, but you have to fix it with glue, the needlework will not work here.



November 2010

On a lathe I made two new coilforms to wind coils. Both have two rows of 15 holes in it to put in some knitting pins to wind the wire around.

The sizes are as mentioned in old books for the coils mentioned above, one 4.5cm thick and one 2.5cm thick with a inner diam of 5cm.

Winding method: Over two, directly to other side and again over two at the other side. (over 2/under 0)

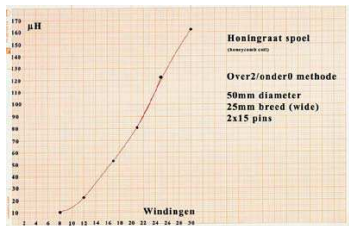

I wound the smallest coil mentioned above (2.5cm wide). Precisely according to the description in the books with 25 windings. The value should be 50µH, but after I measured it with my AADE meter and another LCR bridge the value was around 122µH. Same for wire length, I took 4 meters and wound the coil till I got no wire left,..8 windings with a value of 12µH. So just wind your coil, measure and put some more wire on it or take some windings off till you get what you want.

For the above honeycomb coil I made a table for future use when I need to make some coils. I made 3 and put the value and windings on mm-paper, I connected the points to get a rough guess of inbetween points.

Then I made the coils I needed and measured them and also put them inside the table. It only goes to 162µH because I didn't wind a bigger one.

Table is for honeycomb coils using the "Over2/Under0" method, wound onto a 5cm in diameter form, 2.5cm wide with 2x15 pins.

was resonant at 11.110Mhz. -3dB point was at 11.220 and 10.930, this makes a bandwidth of 290khz.

So this is the frequency where the coil is resonant with it's own capacitance. The Q of this coil is $11.110\text{mhz}/0.29\text{mhz}=38$ Not really a good choice to use for a chort wave crystal receiver.

Its own capacitance is approx. 13pF.

If I use this coil on shortwave, the selectivity would go any better then this 290khz. Q is only getting better at a lower frequency.

I also measured the self resonance of my 440x46 spiderweb coil of my 2006 BTTF receiver.

Resonant at 2.523Mhz, -3dB point at 2.539 and 2.505Mhz, this makes a bandwidth of 34Khz.

The Q of the coil at this frequency is $2.523/0.034=74$.

Here I see that the Q is much better at lower frequency as i measured in another chapter on my site.

Self capacitance is around 16pF

If I wanted to make myself a 10-15Mhz shortwave crystal receiver with a bandwidth of around 9Khz, then I would have to use a coil with a Q of around 1300, this means a self resonance point that is at a much higher level, and a even lower capacity,..even lower as 5pF,..I still want to seperate the station,..won't I.

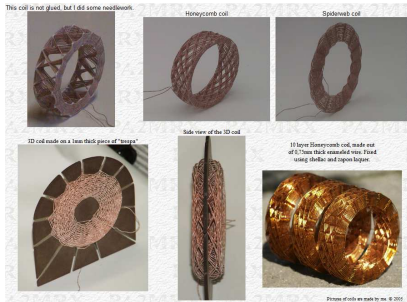

Pictures of coils are made by me. © 2005

Fixation of the coils so they do not fall apart can be done using some needlework, another used methode from the beginning of the 20th century is to fix the coil using "zapon-laquer". This a laquer on a nitrocellulose basis. Long time ago you could make this yourself by dissolving celluloid film negatives into ethanol. Beware: film negatives these days are not made out of celluloid. Now you submerge the coil into the solution you get and after that you get it out of the solution and let it dry. You also can use "shellac" to fixate the coils, this is available plentyfull on Ebay,..a kilo for 8 Euro`s or so.

Self resonance of coils

I made a cilinder aircoil with a value of $15\mu\text{H}$. Without a capacitor connected I measured the resonance of this coil. It



The basket weave coil. (Lorenz coil)

You can create your basket weave coils using a piece of wood or something. I used a piece of plexiglass with a thickness of around 1cm and drilled holes in it, I used steel nails to put in the holes. The nails are placed in a circle of around 12cm. I wound the wire around the nails using the over1/under2 methode. But this can be

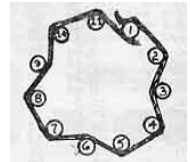
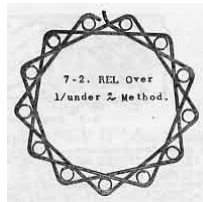

re-arranged by you using anothe method,..over1/under1, over1/under3,..you name it.

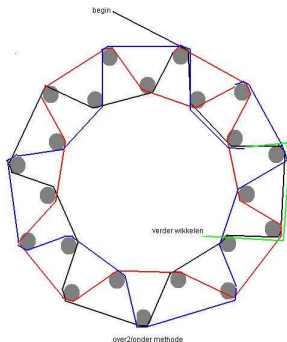

Another type of coil is the basket weave coil made using two rings of nails to wind your wire through. At the right you see 2x11 steel nails. The methode of winding here is over2/under2, but you also can use over1/under2 or something else.

Note: Of you follow the wire in the over2/under2 methode, you get to the starting point after 3 circulations of the wire. Now you layed down just one layer. This also includes the coils mentioned above.

This is what they mean by the windings do not see eachother, there is lots of air between every layer, this gives you a coil with a better Q.

This way I made several basket weave coils and some of these had one layer after 8 windings.

In table 1 they used 25 windings and 4meters of wire on a coilform of 5cm in diameter. These 25 windings are the windings,..not the layers. You have to watch out not lay down 25 layers.

A basket weave coil stays the same diameter while the width is getting more.

Below some pictures of coils I made and on their form. (this is my first and old coilform)

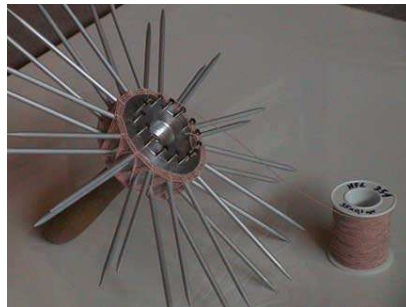

Coil being made using the form with knitting pins